



To: Town of Munster Plan Commission
Attorney Nicole Bennett

From: Sergio Mendoza, Planning Director

Date: February 11, 2023

Re: PC24-012 Staff Report addendum

At the January 14, 2025 Plan Commission Meeting Vice President Raffin moved to grant APPROVAL of PC 24-012 CONTINGENT upon the submission and approval by the Plan Commission the following further discussion items:

1. A new landscaping plan that includes Phase 1 only; there is no Phase 2. Updated plan should also show the sidewalk installed along Columbia Avenue and existing ones on Otis Bowen Drive
2. Updated lighting and plan with intent to comply with current code or seek a BZA variance
3. Signage Plan
4. Plan for mechanical screening throughout the property.

For your reference, as it relates to the Plan Commission Motion, please find attached and below findings from the above motion:

Condition 1: A landscaping plan submitted can be found on page 20 of their December 10, 2024 Staff Report, which does not identify a “phase 2” as requested, a sidewalk is identified on the site plan found on page 32 of their December 10, 2024 Staff Report. An updated landscaping plan with sidewalks has been submitted and attached as part of this memo.

Condition 2: A lighting plan submitted can be found on pages 21 and 22, and a more detailed lighting plan on pages 46-60 of their December 10, 2024 Staff Report. The applicant has submitted a BZA Variance Application for the requested updated lighting plans which are attached as part of this memo.

Condition 3: A sign plan can be found on page 45 of the 12.10.24 staff report. The applicant was advised to forward any additional signage, i.e. wall signs, canopy signs, etc. A sign plan

and sign permit has been submitted and staff notes variance will be required. Sign plan has been submitted and attached as part of this memo.

Condition 4: A mechanical screening plan has been submitted and has been submitted and attached as part of this memo.

Please find attached:

- Landscape and Sidewalk Plan, updated
- Lighting Plan, updated
- Signage proposal
- Mechanical Screening Plan

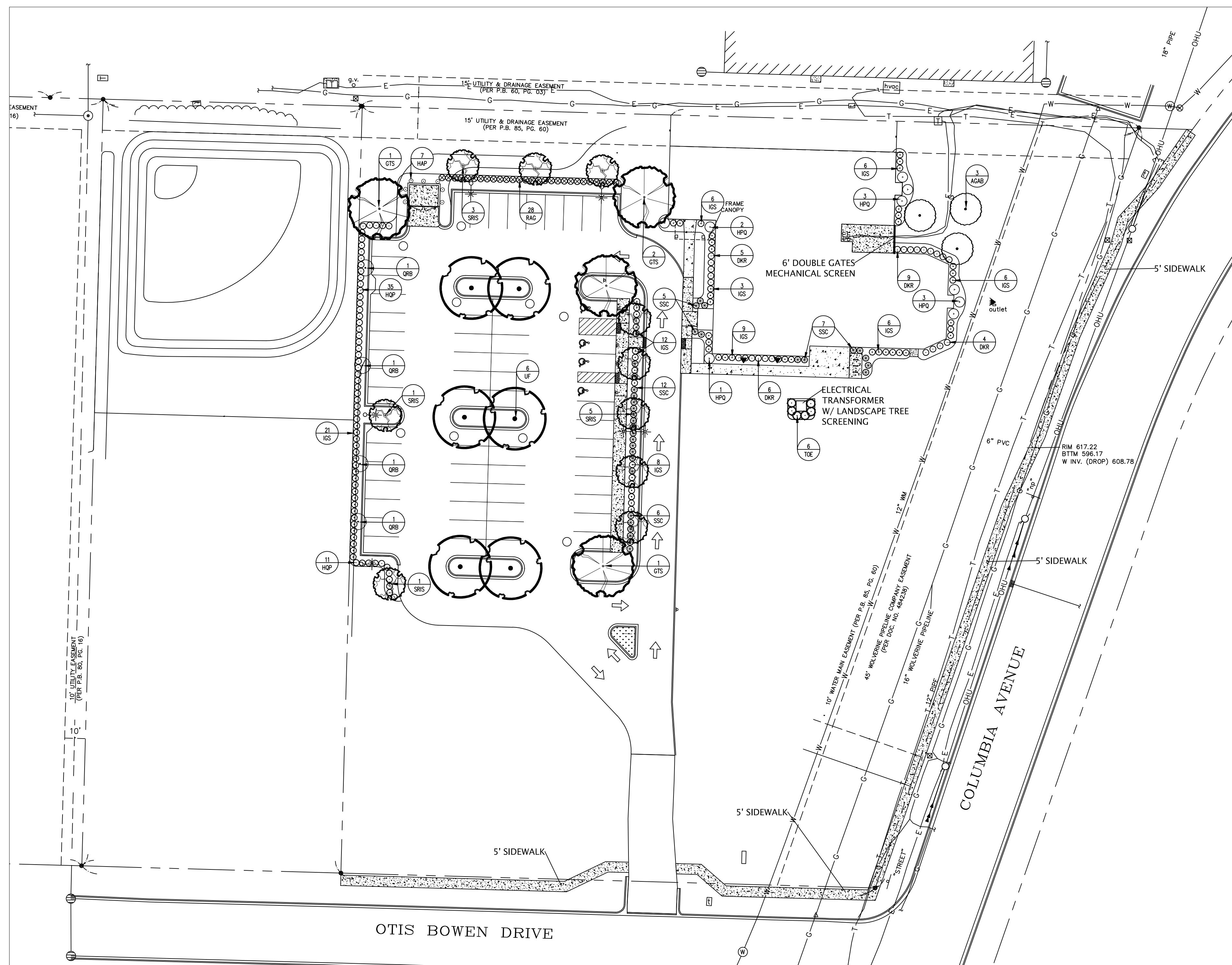

LOCATE ALL UNDERGROUND UTILITIES PRIOR TO DIGGING. SHRUB PIT WIDTH TO BE TWO TIMES THE WIDTH OF THE ROOT BALL. PRUNE OFF ALL DEAD, BROKEN OR SCARRED BRANCHES, AND SHAPE PRUNE AS DIRECTED BY THE LANDSCAPE ARCHITECT. LOCATE ROOT FLARE IN ROOT BALL AND SET SHRUB HEIGHT SO THAT ROOT FLARE IS FLUSH OR SLIGHTLY HIGHER THAN FINISH GRADE DEPENDING ON EXISTING SOIL CONDITIONS. WATER IN THE PLANTING MIX THOROUGHLY, WHILE KEEPING THE SHRUB PLUMB. STRAIGHTEN SHRUB IF SETTLING OCCURS. MULCH LIMITS FOR SHRUBS TO EXTEND TO ALL EDGES OF PLANTING BEDS. SEE PLANS FOR BED LAYOUTS.

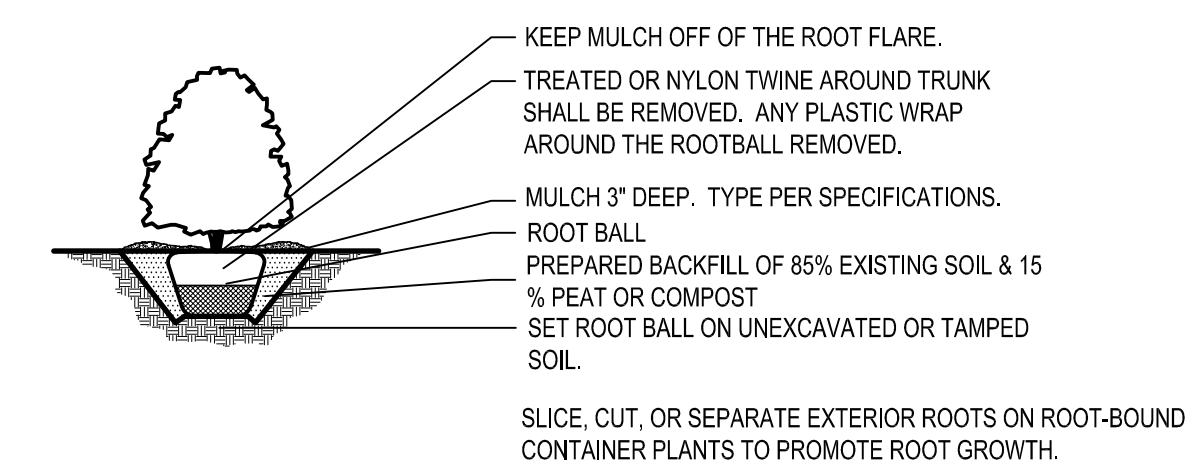

1 SHRUB PLANTING DETAIL
NOT TO SCALE

LOCATE ALL UNDERGROUND UTILITIES PRIOR TO DIGGING. TREE PIT WIDTH TO BE TWO TIMES THE WIDTH OF THE ROOT BALL. PRUNE OFF ALL DEAD, BROKEN OR SCARRED BRANCHES, AND SHAPE PRUNE AS DIRECTED BY THE LANDSCAPE ARCHITECT. LOCATE ROOT FLARE IN ROOT BALL AND SET TREE HEIGHT SO THAT ROOT FLARE IS FLUSH OR SLIGHTLY HIGHER THAN FINISH GRADE DEPENDING ON EXISTING SOIL CONDITIONS. WATER IN THE PLANTING MIX THOROUGHLY, WHILE KEEPING THE TREE PLUMB. STRAIGHTEN TREE IF SETTLING OCCURS.

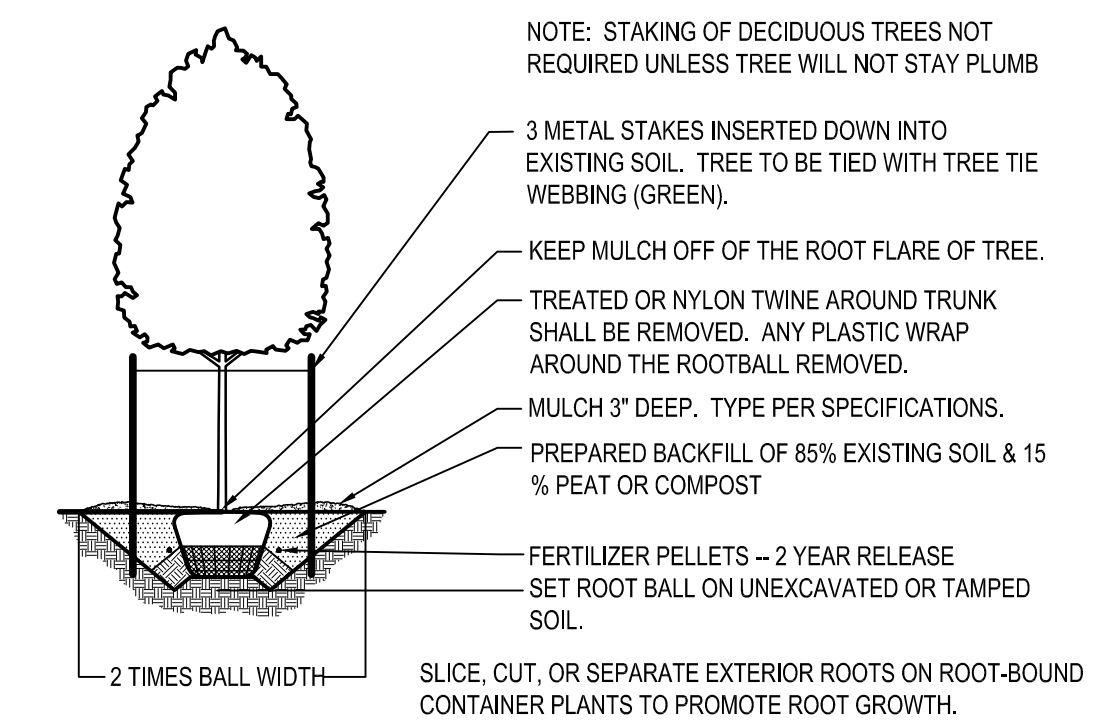

2 DECIDUOUS & EVERGREEN TREE PLANTING DETAIL
NOT TO SCALE

LOCATE ALL UNDERGROUND UTILITIES PRIOR TO DIGGING. AMEND PLANTING BED SOIL WITH COMPOST PRIOR TO PLANT INSTALLATION. BED HEIGHT IS TO BE 2\"/>

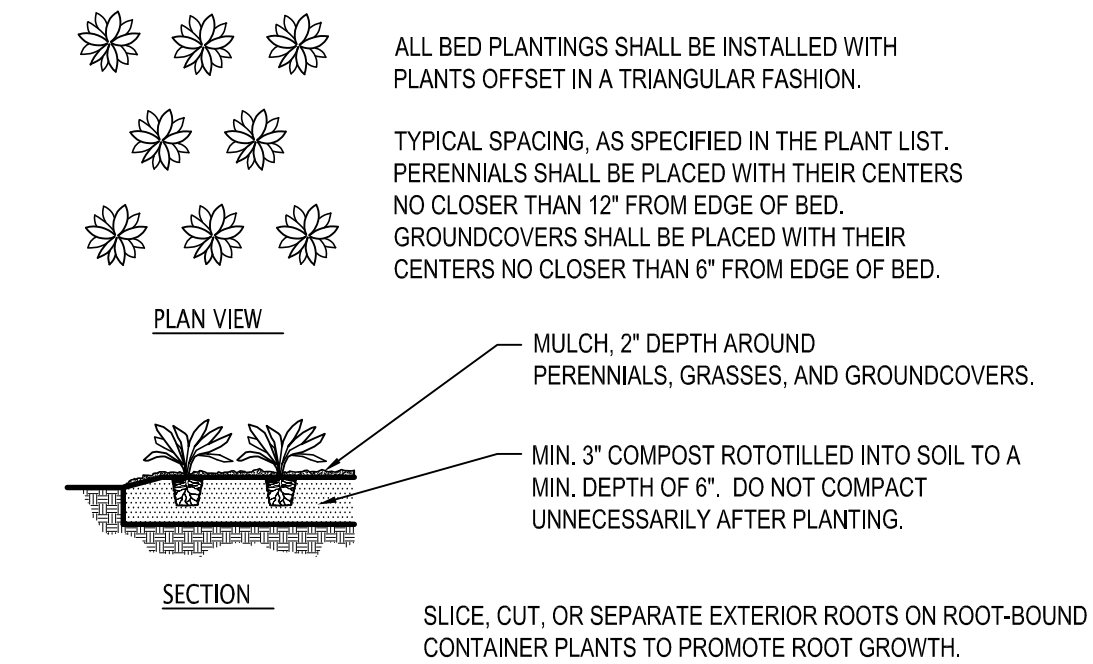

3 PERENNIAL, GROUNDCOVER, AND ANNUAL PLANTING DETAIL
NOT TO SCALE

This Drawing and Design is the Property of Hubinger Landscaping Corp. and is not to be reproduced or used without the permission of Hubinger Landscaping Corp.

Notes:
Stand alone trees and Landscape Areas to have Shredded Hardwood Bark Mulch 3\"/>

All disturbed lawn areas to be restored w/ 4\"/>

Starter fertilizer to be applied at installation and post fertilizer application applied 30-45 days later with a minimum of 1# of Nitrogen per 1000 SF and 50% being slow release.

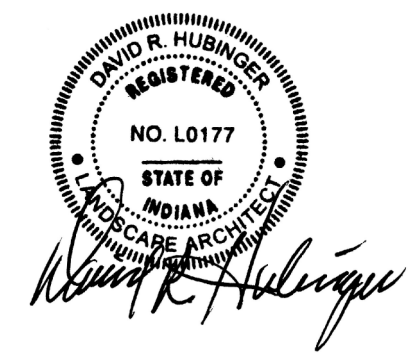

LANDSCAPE UPDATE	1-21-25
LANDSCAPE UPDATE	9-19-24
SITE CHANGES	7-12-24
SITE CHANGES	3-1-24
Revisions:	Date

HUBINGER
Landscaping
Corp.

210 East 113th Avenue
Crown Point, Indiana
Phone: 219-662-9911
www.hubingers.com

OSNI MEDICAL OFFICE
9900 COLUMBIA AVE.
MUNSTER, IN

Drawn By: LBK/SAS
Date: 10/11/23
Scale: 1:30
L1.0

Symbol	Botanical Name	Common Name	Size
Trees			
GTS	Gleditsia triacanthos var. inermis 'Skycole'	Skyline Locust	2.5"
QRB	Quercus x 'Nadler'	Kindred Spirit Oak	2.5"
SRS	Syringa reticulata 'Ivory Silk'	Ivory Silk Lilac	2.5"
TOE	Thuja occidentalis 'Smaragd'	Emerald Green Arborvitae	5-6'
UF	Ulmus 'Frontier'	Frontier Elm	2.5"
Shrubs			
DKR	Diervilla 'Kodiak Red'	Kodiak Red Diervilla	#3
HPQ	Hydrangea paniculata 'Quick Fire'	Quick Fire Hydrangea	#3
HQP	Hydrangea quercifolia 'PeeWee'	PeeWee Hydrangea	#3
IGS	Ilex glabra 'Strongbox'	Strongbox Inkberry	#3
RAG	Ribes alpinum 'Green Mound'	Green Mound Alpine Currant	#3
Vine			
HAP	Hydrangea anomala ssp. petiolaris	Climbing Hydrangea	#3
Perennials			
SSC	Schizachyrium scoparium 'Carousel'	Carousel Little Blue Stem Grass	#2

LANDSCAPE REQUIREMENTS						
Calculations	Total Linear Feet (LF) or Square Feet (SF)	Trees Required	Trees Provided	Shrubs Required	Shrubs Provided	
Parking Planting						
Continuous Screening Hedge 7' Wide Required	Provided					
1 Tree / 125 SF Internal Landscaping	2530 SF	20	20			
All Masonry Dumpster Walls to Have Climbing Vines	Provided					

The undersigned landscape architect, registered in the State of Indiana, acknowledges that the landscape planting plan and construction details shown on the attached landscape plan for the property at 9900 Columbia Ave., Town of Munster, Indiana has been designed in accordance with the requirements of the Town of Munster Municipal Code, the landscaping standards of the Town of Munster Zoning Ordinance, and the Guide to the Town of Munster Landscape Ordinances.

David R. Hubinger

NORTH

GRAPHIC SCALE
0 15 30 60 120
(IN FEET)
1 inch = 30 ft.

HOLEY MOLEY SAYS
"DIG SAFELY"

"IT'S THE LAW"
CALL 2 WORKING DAYS BEFORE YOU DIG
1-800-382-5544
CALL TOLL FREE
PER INDIANA STATE LAW ICR-1-26,
IT IS AGAINST THE LAW TO EXCAVATE
WITHOUT NOTIFYING THE UNDERGROUND
LOCATION SERVICE TWO (2) WORKING
DAYS BEFORE COMMENCING WORK.

Legacy Designs, Inc.
 555 S. Perryville Road
 Rockford, IL 61108
 Phone: 815-484-4708
 Fax: 815-484-4710
 e-mail: legacy@legacidesigns.net
 www.legacidesigns.net

RIDGELAND ASSOCIATES INC.
 ARCHITECTS DESIGNERS PLANNERS
 1 Riverside Rd., Riverside, Illinois 60546
 708.435.0300 708.435.0305 fax
 www.ridgelandassociates.com

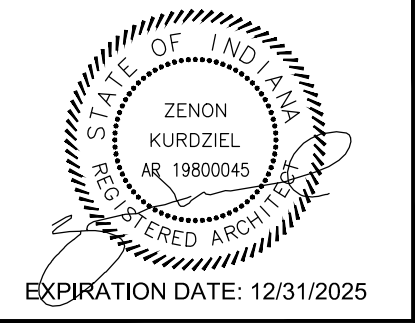

EAI
 DESIGN/BUILD
E.ANTHONY, INC.
 Complete Construction Services
 708-602-8280

OSNI
 BUILDING RENOVATION AND SITE WORK
 9900 COLUMBIA AVENUE, MUNSTER, INDIANA 46321

Revisions

Drawing Date: 8-5-2024
 Project Number: 24038

This document is an instrument of service and is the sole property of Ridgeland Associates, Inc. It may not be copied, reproduced, altered or revised in whole or in part on any other project without expressed written consent from Ridgeland Associates, Inc.

Sheet Name: PHOTOMETRIC SITE PLAN
 Sheet Number: **ES102**
 © 2024 Ridgeland Associates, Inc.

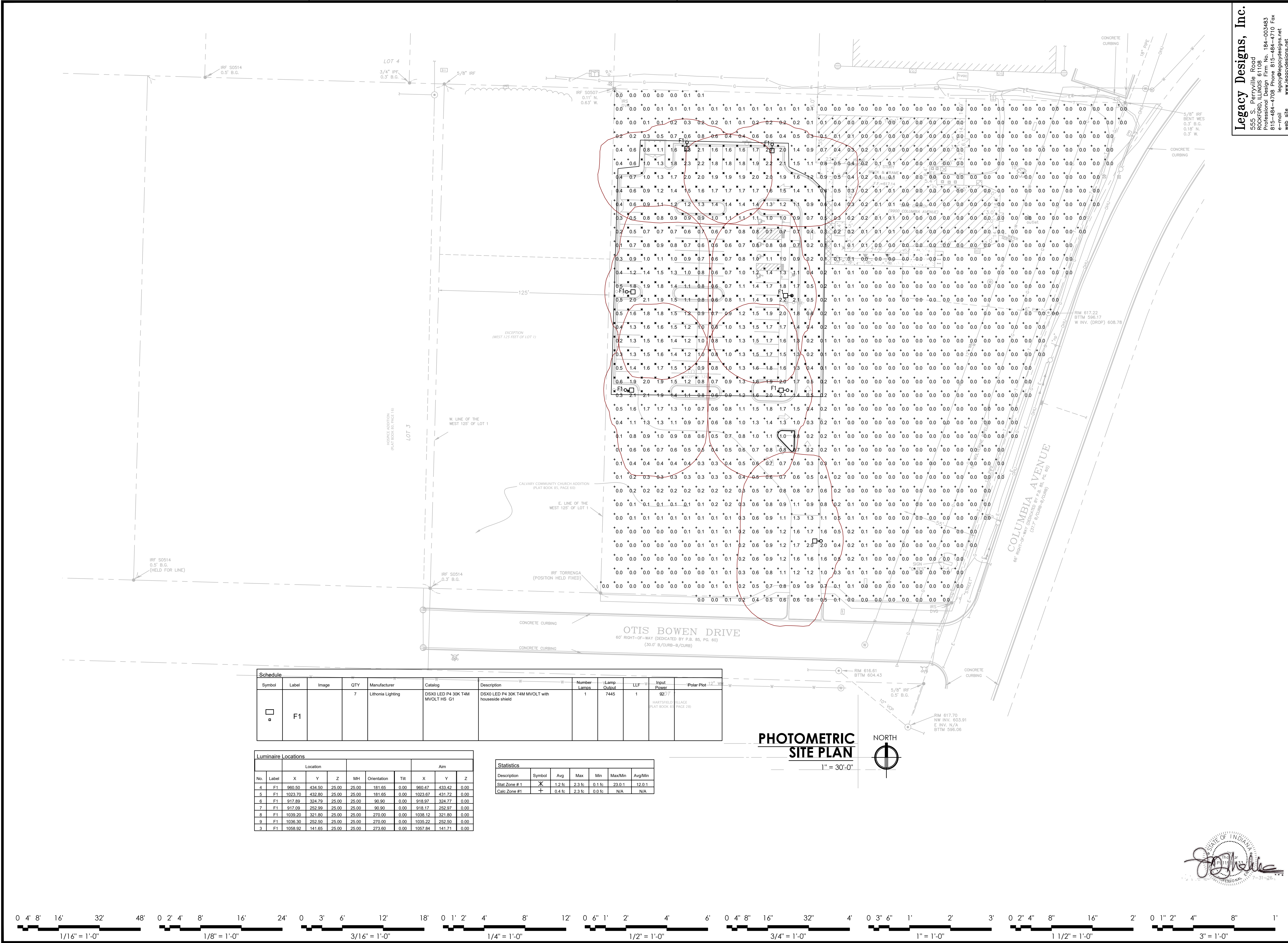

Symbol	Label	Image	QTY	Manufacturer	Catalog	Description	Number Lamps	Lamp Output	LLF	Input Power	Polar Plot 12"
	F1		7	Lithonia Lighting	DSXO LED P4 30K T4M MVOLT HS G1	DSXO LED P4 30K T4M MVOLT with houseshield	1	7445	1	92.71	MANTLED RELACE (PLAT BOOK 83, PAGE 28)

No.	Label	Location				Aim				
		X	Y	Z	MH	Orientation	Tilt	X	Y	Z
4	F1	960.50	434.59	25.00	25.00	181.65	0.00	960.47	433.42	0.00
5	F1	1023.70	432.86	25.00	25.00	181.65	0.00	1023.67	431.72	0.00
6	F1	917.89	334.79	25.00	25.00	90.90	0.00	918.97	334.77	0.00
7	F1	917.09	252.99	25.00	25.00	90.90	0.00	918.17	252.97	0.00
8	F1	1039.20	321.80	25.00	25.00	270.00	0.00	1038.12	321.80	0.00
9	F1	1038.30	252.50	25.00	25.00	270.00	0.00	1035.22	252.50	0.00
3	F1	1058.92	141.65	25.00	25.00	273.60	0.00	1057.84	141.71	0.00

Statistics						
Description	Symbol	Avg	Max	Min	Max/Min	Avg/Min
Stat Zone #1	X	1.2 fc	2.3 fc	0.1 fc	23.0:1	12.0:1
Calc Zone #1	+	0.4 fc	2.3 fc	0.0 fc	N/A	N/A

PHOTOMETRIC SITE PLAN
 1" = 30'-0"

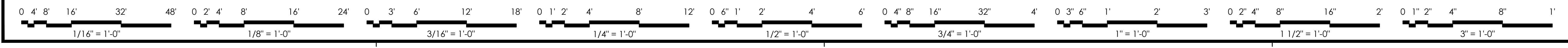

Submitted by Leslie Nowalski

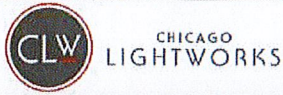

Job Name:
ORTHOPEDIC SPECIALISTS OF
NWJ OSNI
Electrical Contractor: PALOS
ELECTRIC-CRESTWOOD

Catalog Number:
OPF-S-A05-840-T4M-AR1-UNV-BZ

Type:
F1

Notes:

CLW24-28520



Site and Area

OptiForm

OPF-S Small

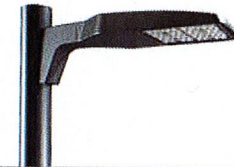

Gardco OptiForm site and area luminaires are available in three sizes: small, medium and large. Featuring the latest in LED technology, OptiForm achieves up to 192 lumens per watt. Eleven optical distributions are available, suitable for a range of outdoor lighting applications. OptiForm features a unique mounting system with a two-piece housing for hassle-free installation. Mounting options include a standard arm, mast arm, and wall mount bracket. Service Tag is a standard feature with every OptiForm luminaire, providing maintenance or upgrade assistance throughout the life of the product.

Project: _____
 Location: _____
 Cat No: _____
 Type: _____
 Lamps: _____ Qty: _____
 Notes: _____

Ordering guide

example: OPF-S-A01-840-T4M-AR1-120-BL50-L3-BZ

Luminaire	Configuration (nom. lumens)		Color Temperature		Distribution				Mounting	Voltage	
OPF-S											
OPF-S OptiForm Small Area	Site and Area	Precision Plus[®] (T2M, T3M, T4M, T5M only)	827¹	80CRI 2700K	AFR	Autofront row	LCL	LEED corner optic left	AR1^{2,7}	Arm mount (standard)	120 120V
	A01 7,000 lumens	P01 2,500 lumens	830	80CRI 3000K	T2M	Type 2 medium	LCR	LEED corner optic right		MAR³	Mast arm
	A02 9,000 lumens	P02 4,000 lumens	840	80CRI 4000K	T3M	Type 3 medium	BLC	Back light control		WAL	Wall mount
	A03 11,000 lumens	P03 6,500 lumens	727¹	70CRI 2700K	T4M	Type 4 medium	2RL	Type 2 rotated left 90°		MCS⁴	Mounting ordered separately
	A04 15,000 lumens	P04 9,000 lumens	730	70CRI 3000K	T4W	Type 4 wide	2RR	Type 2 rotated right 270°			
	A05 17,000 lumens	P05 11,500 lumens	740	70CRI 4000K	T5N	Type 5 narrow	3RL	Type 3 rotated left 90°			347 347V
	A06 19,000 lumens	P06 14,000 lumens	750	70CRI 5000K	T5M	Type 5 medium	3RR	Type 3 rotated right 270°			480 480V
	A07 20,000 lumens	P07 16,500 lumens			T5W	Type 5 wide	4RL¹	Type 4 rotated left 90°			UNV 120-277V
		P08 19,000 lumens					4RR¹	Type 4 rotated right 270°			HVU¹⁶ 347-480V
		P09 22,000 lumens									

Dimming Controls	Sensing	Options (electrical, mechanical, etc)	Emergency	Finish
The following options include 0-10V Driver		None	EM ^{12,14,15}	Standard textured finish
none	0-10V dimming driver	SP2 Surge protector 20kV/10kA (option)	Emergency Battery Pack (0-40 °C)	BK Black
DLEA ^{5,30}	Dimming leads externally accessible (controls by others)	FS1 ⁹ Single fuse (120, 277, or 347VAC)	Available with precision plus optics P01-P03 only	WH White
FAWS ^{5,30}	Field adjustable wattage selector	FS2 ⁷ Double fuse (208, 240, or 480V)		BZ Bronze
BL50 ^{5,30}	Bi-level with motion sensor	PCB ^{8,12} Photocontrol button connected to 0-10V driver		DG Dark Gray
	L2 PIR sensor, #2 lens (Required if BL50 is selected)	TR5 NEMA Twist-lock 5-pin receptacle connected to 0-10V driver		MG Medium Gray
The following options include SR/DALI Driver		TR7 ¹³ 7-pin twist lock receptacle connected to DALI compliant driver		Customer specified
SRDR ^{5,3,13}	SR driver connected to Zhaga socket (DALI)	TLP ^{11,13} 7-pin twist lock receptacle connected to DALI compliant driver w/ 3-pin photocell		OC Special optional color or RAL, consult factory
OMSR ^{5,3,13}	Outdoor multi-sensor	EHS Housing machined to accept external house side shield for field install. Must be combined with OPF-S-EHS-1 accessory.		SC Special color (must supply color chip, requires factory quote)
DynaDimmer: Automatic Profile Dimming				
CS50 ^{5,13}	Security 50% dimming, 7 hours			
CM50 ^{5,13}	Median 50% dimming, 8 hours			
CS30 ^{5,13}	Security 30% dimming, 7 hours			
CM30 ^{5,13}	Median 30% dimming, 8 hours			

- Extended leadtime applies. Consult factory for details.
- Mounts to a square pole with knockout for 4-5" OD round pole.
- Mounts to a horizontal 2-3/8" OD x 5" Long tenon.
- Must be ordered with mounting accessory. Photocell option (TR7) must be selected with mounting accessory. See Page 2 for options.
- Not available with other dimming control options (mutually exclusive).
- Not available with motion sensor (physical restriction).
- Must be specified with a motion sensor lens (L2).
- Not available with PCB, TR5.
- Must be specified with a motion sensor LW, LB.
- Not available with TR7, TLP.

- Must specify input voltage.
- Not available in HVU [347-480V].
- UNV [120-277V] only available for lumen packages P03-P09. HVU [347-480V] only available for lumen packages P06-P09 & A04-A07.
- UNV [120-277V] only available for lumen packages P04-P09.
- Not available with Dynadimmer, SRDR, FAWS, FS1, FS2, OMSR, DLEA, BL50 (physical restriction).
- Precision Plus Optics (P01-P09) available only with T2M, T3M, T4M, and T5M optical distributions and are non-rotatable.
- OPF-RMB accessory recommended for retrofit applications.





OPF-S OptiForm small

Site & area luminaire

Shielding Accessory Kits (order separately)

One shield kit per luminaire

- OPF-S-EHS-1* External house side shield (field installed)
- OPF-S-HIS-1** Internal house side shields. For Area optic types T2M, T3M, and T5N.
- OPF-S-HIS-T4-1** Internal house side shield for Area optic types T4M and T4W, qty 1.
- OPF-S-HIS-5M/5W-1** Internal house side shield for Area optic types T5M and T5W, qty 1

*Must select EHS option on luminaire options section

**Not available for Precision Plus (P01-P09)

Mounting Accessories

- OPF-RMB Retrofit Mounting Bolster Plate for attaching OptiForm to existing poles. Recommended for retrofit applications.
- OPF-RPA Round Pole Adapter. Fits to 3" - 3.9" O.D. pole. Painted black.

Luminaire Accessories (order separately)

Pole Mount Fusing

- FP1 Pole mount single fuse (120V, 277V, or 347V)
- FP2 Pole mount double fuse (208V, 240V, or 480V)
- FP3 Pole mount double fuse canadian double pull (208V, 240V, or 480V)

Photocell Accessories

- P400S Shorting cap

Pole Top Fitters

PTF2 - Pole top fitter fits 2 3/8 - 2 1/2" OD x 4" depth tenon

- PTF2-1-90-(F) 1 luminaire at 90°
- PTF2-2-90-(F) 2 luminaires at 90°
- PTF2-3-90-(F) 3 luminaires at 90°
- PTF2-4-90-(F) 4 luminaires at 90°
- PTF2-2-180-(F) 2 luminaires at 180°
- PTF2-3-120-(F) 3 luminaires at 120°

PTF3 - Pole top fitter fits 3-3 1/2" OD x 6" depth tenon

- PTF3-1-90-(F) 1 luminaire at 90°
- PTF3-2-90-(F) 2 luminaires at 90°
- PTF3-3-90-(F) 3 luminaires at 90°
- PTF3-4-90-(F) 4 luminaires at 90°
- PTF3-2-180-(F) 2 luminaires at 180°
- PTF3-3-120-(F) 3 luminaires at 120°

Mountings (boxed and shipped separately)

Must choose Mounting Ordered Separately (MOS) selection for mounting option of luminaire. Useful for attachment of arm to pole prior to luminaire installation.

Standard Arm

- OPF-AR1-(F)^{2,7} Standard arm mount
- OPF-AR1-TR7-(F)^{2,3,7} Mast arm mount with 7-pin (TR7) receptacle

Wall Mount

- OPF-WAL-(F) Wall mount bracket
- OPF-WAL-TR7-(F)³ Wall mount with 7-pin (TR7) receptacle

Mast Arm

- OPF-MAR-(F)³ Mast arm mount
- OPF-MAR-TR7-(F)^{3,3} Mast arm mount with 7-pin (TR7) receptacle

Optical Distributions

Site and Area Optics

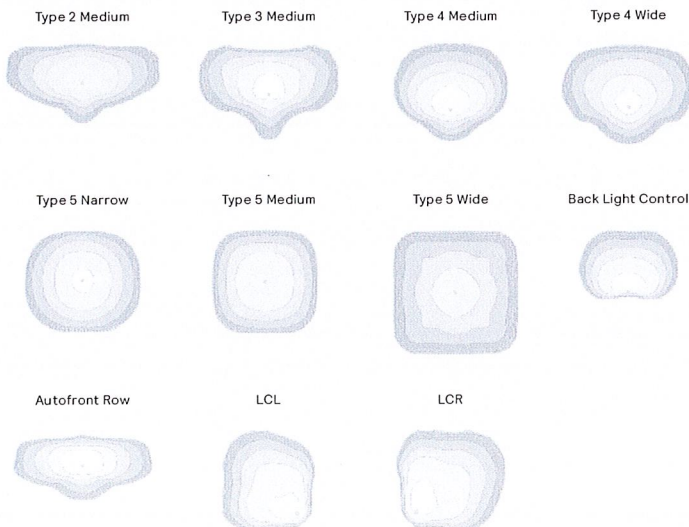

Precision Plus Optics

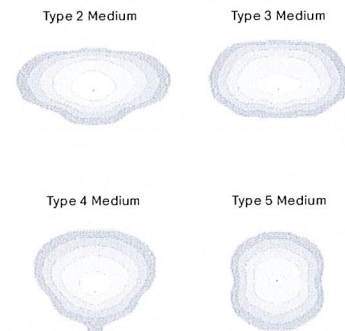

Submitted by Leslie Nowalski



CHICAGO
LIGHTWORKS

Job Name:
ORTHOPEDIC SPECIALISTS OF
NWI OSNI
Electrical Contractor: PALOS
ELECTRIC-CRESTWOOD

Catalog Number:
OPF-S-A05-840-T4M-AR1-UNV-BZ

Notes:

Type:

F1

CLW24-28520

OPF-S OptiForm small

Site & area luminaire

OPF-S Area Optic Lumen values

Performance Package	System Watts	Distribution Type	70 CRI			70 CRI			70 CRI		
			3000K			4000K			5000K		
			Lumen Output	BUG Rating	Efficacy (LPW)	Lumen Output	BUG Rating	Efficacy (LPW)	Lumen Output	BUG Rating	Efficacy (LPW)
A01	42	T2M	6991	B2-U0-G2	167	7391	B2-U0-G2	176	7391	B2-U0-G2	176
		T3M	6935	B2-U0-G2	166	7332	B2-U0-G2	175	7332	B2-U0-G2	175
		T4M	7028	B1-U0-G2	168	7431	B1-U0-G2	177	7431	B1-U0-G2	177
		T5M	7244	B3-U0-G1	173	7659	B3-U0-G1	183	7659	B3-U0-G1	183
		AFR	7241	B2-U0-G2	173	7655	B2-U0-G2	183	7655	B2-U0-G2	183
		T4W	6692	B1-U0-G2	160	7075	B1-U0-G2	169	7075	B1-U0-G2	169
		T5N	7193	B3-U0-G1	172	7605	B3-U0-G1	182	7605	B3-U0-G1	182
		T5W	6926	B3-U0-G2	165	7322	B3-U0-G2	175	7322	B3-U0-G2	175
		LCL	3804	B1-U0-G1	91	4021	B1-U0-G1	96	4021	B1-U0-G1	96
		LCR	3804	B1-U0-G1	91	4021	B1-U0-G1	96	4021	B1-U0-G1	96
BLC	4874	B0-U0-G1	116	5153	B0-U0-G1	123	5153	B0-U0-G1	123		
A02	54	T2M	8941	B2-U0-G2	165	9452	B2-U0-G2	175	9452	B2-U0-G2	175
		T3M	8869	B2-U0-G2	164	9377	B2-U0-G2	173	9377	B2-U0-G2	173
		T4M	8989	B1-U0-G2	166	9503	B1-U0-G2	176	9503	B1-U0-G2	176
		T5M	9265	B3-U0-G2	171	9795	B3-U0-G2	181	9795	B3-U0-G2	181
		AFR	9260	B2-U0-G2	171	9790	B2-U0-G2	181	9790	B2-U0-G2	181
		T4W	8558	B2-U0-G2	158	9048	B2-U0-G2	167	9048	B2-U0-G2	167
		T5N	9200	B3-U0-G1	170	9726	B3-U0-G1	180	9726	B3-U0-G1	180
		T5W	8858	B3-U0-G2	164	9365	B3-U0-G2	173	9365	B3-U0-G2	173
		LCL	4864	B1-U0-G1	90	5143	B1-U0-G1	95	5143	B1-U0-G1	95
		LCR	4864	B1-U0-G1	90	5143	B1-U0-G1	95	5143	B1-U0-G1	95
BLC	6234	B0-U0-G2	115	6591	B0-U0-G2	122	6591	B0-U0-G2	122		
A03	54	T2M	10438	B2-U0-G2	164	11035	B2-U0-G2	174	11035	B3-U0-G3	174
		T3M	10354	B2-U0-G2	163	10947	B2-U0-G2	172	10947	B2-U0-G2	172
		T4M	10494	B2-U0-G2	165	11094	B1-U0-G2	174	11094	B2-U0-G2	174
		T5M	10816	B3-U0-G2	170	11435	B3-U0-G2	180	11435	B3-U0-G2	180
		AFR	10811	B3-U0-G3	170	11429	B2-U0-G2	180	11429	B3-U0-G3	180
		T4W	9991	B2-U0-G3	157	10563	B2-U0-G2	166	10563	B2-U0-G3	166
		T5N	10740	B3-U0-G2	169	11355	B3-U0-G1	179	11355	B3-U0-G2	179
		T5W	10341	B4-U0-G2	163	10933	B3-U0-G2	172	10933	B4-U0-G2	172
		LCL	5679	B1-U0-G1	89	6004	B1-U0-G1	94	6004	B1-U0-G1	94
		LCR	5679	B1-U0-G1	89	6004	B1-U0-G1	94	6004	B1-U0-G1	94
BLC	7278	B1-U0-G2	114	7694	B0-U0-G2	121	7694	B1-U0-G2	121		
A04	91	T2M	14465	B3-U0-G3	160	15293	B3-U0-G3	169	15293	B3-U0-G3	169
		T3M	14350	B3-U0-G3	158	15171	B3-U0-G3	167	15171	B3-U0-G3	167
		T4M	14543	B2-U0-G2	160	15375	B2-U0-G2	170	15375	B2-U0-G2	170
		T5M	14990	B4-U0-G2	165	15848	B4-U0-G2	175	15848	B4-U0-G2	175
		AFR	14982	B3-U0-G3	165	15840	B3-U0-G3	175	15840	B3-U0-G3	175
		T4W	13847	B2-U0-G3	153	14639	B2-U0-G3	161	14639	B2-U0-G3	161
		T5N	14884	B4-U0-G2	164	15736	B4-U0-G2	174	15736	B4-U0-G2	174
		T5W	14331	B4-U0-G3	158	15151	B4-U0-G3	167	15151	B4-U0-G3	167
		LCL	7870	B1-U0-G2	87	8321	B1-U0-G2	92	8321	B1-U0-G2	92
		LCR	7870	B1-U0-G2	87	8321	B1-U0-G2	92	8321	B1-U0-G2	92
BLC	10086	B1-U0-G2	111	10663	B1-U0-G2	118	10663	B1-U0-G2	118		



OPF-S OptiForm small

Site & area luminaire

OPF-S Area Optic Lumen values (cont'd)

Performance Package	System Watts	Distribution Type	70 CRI			70 CRI			70 CRI		
			3000K			4000K			5000K		
			Lumen Output	BUG Rating	Efficacy (LPW)	Lumen Output	BUG Rating	Efficacy (LPW)	Lumen Output	BUG Rating	Efficacy (LPW)
A05	104	T2M	16226	B3-U0-G3	156	17155	B3-U0-G3	164	17155	B3-U0-G3	164
		T3M	16096	B3-U0-G3	154	17018	B3-U0-G3	163	17018	B3-U0-G3	163
		T4M	16313	B2-U0-G3	156	17247	B2-U0-G3	165	17247	B2-U0-G3	165
		T5M	16814	B4-U0-G2	161	17777	B4-U0-G2	170	17777	B4-U0-G2	170
		AFR	16806	B3-U0-G3	161	17768	B3-U0-G3	170	17768	B3-U0-G3	170
		T4W	15532	B3-U0-G3	149	16421	B3-U0-G3	157	16421	B3-U0-G3	157
		T5N	16696	B4-U0-G2	160	17652	B4-U0-G2	169	17652	B4-U0-G2	169
		T5W	16075	B4-U0-G3	154	16995	B4-U0-G3	163	16995	B4-U0-G3	163
		LCL	8828	B1-U0-G2	85	9333	B1-U0-G2	89	9333	B1-U0-G2	89
		LCR	8828	B1-U0-G2	85	9333	B1-U0-G2	89	9333	B1-U0-G2	89
BLC	11314	B1-U0-G2	108	11961	B1-U0-G2	115	11961	B1-U0-G2	115		
A06	122	T2M	18441	B3-U0-G3	151	19496	B3-U0-G3	160	19496	B3-U0-G3	160
		T3M	18294	B3-U0-G3	150	19341	B3-U0-G3	158	19341	B3-U0-G3	158
		T4M	18540	B3-U0-G3	152	19601	B3-U0-G3	160	19601	B3-U0-G3	160
		T5M	19110	B4-U0-G2	156	20203	B4-U0-G2	165	20203	B4-U0-G2	165
		AFR	19100	B3-U0-G3	156	20193	B3-U0-G3	165	20193	B3-U0-G3	165
		T4W	17652	B3-U0-G3	144	18662	B3-U0-G3	153	18662	B3-U0-G3	153
		T5N	18975	B4-U0-G2	155	20061	B4-U0-G2	164	20061	B4-U0-G2	164
		T5W	18270	B5-U0-G3	150	19315	B5-U0-G3	158	19315	B5-U0-G3	158
		LCL	10033	B2-U0-G2	82	10607	B2-U0-G2	87	10607	B2-U0-G2	87
		LCR	10033	B2-U0-G2	82	10607	B2-U0-G2	87	10607	B2-U0-G2	87
BLC	12858	B1-U0-G2	105	13594	B1-U0-G2	111	13594	B1-U0-G2	111		

OPF-S Precision Plus Optic Lumen values

Performance Package	System Watts	Distribution Type	70 CRI			70 CRI			70 CRI		
			3000K			4000K			5000K		
			Lumen Output	BUG Rating	Efficacy (LPW)	Lumen Output	BUG Rating	Efficacy (LPW)	Lumen Output	BUG Rating	Efficacy (LPW)
P01	15	T2M	2691	B1-U0-G1	182	2845	B1-U0-G1	192	2845	B1-U0-G1	192
		T3M	2718	B1-U0-G1	184	2874	B1-U0-G1	194	2874	B1-U0-G1	194
		T4M	2665	B1-U0-G1	180	2817	B1-U0-G1	190	2817	B1-U0-G1	190
		T5M	2610	B2-U0-G1	176	2759	B2-U0-G1	186	2759	B2-U0-G1	186
P02	23	T2M	4022	B1-U0-G1	178	4252	B1-U0-G1	189	4252	B1-U0-G1	189
		T3M	4062	B1-U0-G1	180	4295	B1-U0-G1	191	4295	B1-U0-G1	191
		T4M	3983	B1-U0-G1	177	4211	B1-U0-G1	187	4211	B1-U0-G1	187
		T5M	3900	B2-U0-G1	173	4124	B2-U0-G1	183	4124	B2-U0-G1	183
P03	38	T2M	6465	B2-U0-G2	169	6835	B2-U0-G2	179	6835	B2-U0-G2	179
		T3M	6530	B2-U0-G2	171	6904	B2-U0-G2	181	6904	B2-U0-G2	181
		T4M	6402	B1-U0-G2	168	6768	B1-U0-G2	177	6768	B1-U0-G2	177
		T5M	6269	B3-U0-G2	164	6629	B3-U0-G2	174	6629	B3-U0-G2	174
P04	53	T2M	8759	B2-U0-G2	165	9261	B2-U0-G2	174	9261	B2-U0-G2	174
		T3M	8848	B2-U0-G2	166	9355	B2-U0-G2	176	9355	B2-U0-G2	176
		T4M	8674	B2-U0-G2	163	9171	B2-U0-G2	172	9171	B2-U0-G2	172
		T5M	8495	B3-U0-G2	160	8982	B3-U0-G2	169	8982	B3-U0-G2	169



OPF-S OptiForm small

Site & area luminaire

OPF-S Area Optic Lumen values (cont'd)

Performance Package	System Watts	Distribution Type	70 CRI			70 CRI			70 CRI		
			3000K			4000K			5000K		
			Lumen Output	BUG Rating	Efficacy (LPW)	Lumen Output	BUG Rating	Efficacy (LPW)	Lumen Output	BUG Rating	Efficacy (LPW)
P05	66	T2M	11253	B2-U0-G2	172	11898	B2-U0-G2	182	11898	B2-U0-G2	182
		T3M	11366	B3-U0-G3	173	12018	B3-U0-G3	183	12018	B3-U0-G3	183
		T4M	11143	B2-U0-G3	170	11782	B2-U0-G3	180	11782	B2-U0-G3	180
		T5M	10913	B3-U0-G2	167	11539	B3-U0-G2	176	11539	B3-U0-G2	176
P06	76	T2M	13987	B3-U0-G3	183	14788	B3-U0-G3	194	14788	B3-U0-G3	194
		T3M	14128	B3-U0-G3	185	14937	B3-U0-G3	196	14937	B3-U0-G3	196
		T4M	13850	B2-U0-G3	182	14644	B2-U0-G3	192	14644	B2-U0-G3	192
		T5M	13564	B4-U0-G3	178	14342	B4-U0-G3	188	14342	B4-U0-G3	188
P07	94	T2M	15850	B3-U0-G3	168	16758	B3-U0-G3	178	16758	B3-U0-G3	178
		T3M	16010	B3-U0-G3	170	16927	B3-U0-G3	180	16927	B3-U0-G3	180
		T4M	15696	B3-U0-G3	167	16595	B3-U0-G3	176	16595	B3-U0-G3	176
		T5M	15372	B4-U0-G3	163	16253	B4-U0-G3	172	16253	B4-U0-G3	172
P08	113	T2M	19800	B3-U0-G3	176	20934	B3-U0-G3	186	20934	B3-U0-G3	186
		T3M	19999	B3-U0-G3	178	21145	B3-U0-G3	188	21145	B3-U0-G3	188
		T4M	19607	B3-U0-G3	174	20730	B3-U0-G3	184	20730	B3-U0-G3	184
		T5M	19202	B4-U0-G3	171	20302	B4-U0-G3	180	20302	B4-U0-G3	180
P09	133	T2M	21655	B3-U0-G3	163	22896	B3-U0-G3	172	22896	B3-U0-G3	172
		T3M	21874	B3-U0-G3	164	23127	B3-U0-G3	174	23127	B3-U0-G3	174
		T4M	21444	B3-U0-G4	161	22673	B3-U0-G4	171	22673	B3-U0-G4	171
		T5M	21002	B4-U0-G3	158	22205	B4-U0-G3	167	22205	B4-U0-G3	167

LED Wattage and Lumen Values (Emergency Mode)

Ordering Code	CCT	CRI	Avg. System Wattage (W)	Type 2M		Type 3M		Type 4M	
				Lumen Output	BUG Rating	Lumen Output	BUG Rating	Lumen Output	BUG Rating
OPF-S-PXX-740-X-EM	4000	70	6	1000	B0-U0-G0	1014	B0-U0-G1	838	B0-U0-G0
OPF-S-PXX-750-X-EM	5000	70	6	960	B0-U0-G0	973	B0-U0-G1	804	B0-U0-G0
OPF-S-PXX-830-X-EM	3000	80	6	856	B0-U0-G0	868	B0-U0-G1	717	B0-U0-G0
OPF-S-PXX-840-X-EM	4000	80	6	887	B0-U0-G0	899	B0-U0-G1	743	B0-U0-G0

Dimensions

Standard Drill Pattern

Drill Template #5

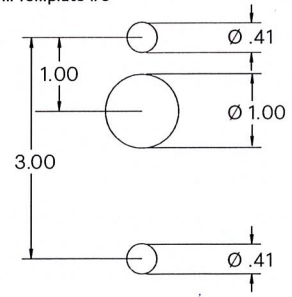

Standard Arm Mounting Hole Pattern

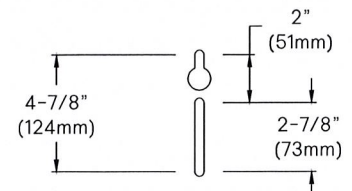

Predicted Lumen Depreciation Data

Predicted performance derived from LED manufacturer's data and engineering design estimates, based on IESNA LM-80 methodology. Actual experience may vary due to field application conditions. L70 is the predicted time when LED performance depreciates to 70% of initial lumen output. Calculated per IESNA TM21-11. Published L70 hours limited to 6 times actual LED test hours

Ambient Temp°C	Lumen Package	Calculated L70 Hours	L70 per TM-21	Lumen Maintenance % at 60,000 hrs
25°C	A06-A07	>77,000 hours	>77,000 hours	90%
25°C	All others	>100,000 hours	>100,000 hours	96%



OPF-S OptiForm small

Site & area luminaire

Dimensions

OptiForm Standard Arm

Weight: 11 lb (5.0 kg)

EPA: 0.2 ft² (0.018 m²)

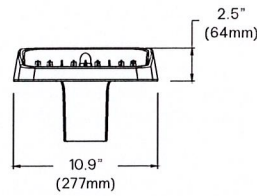
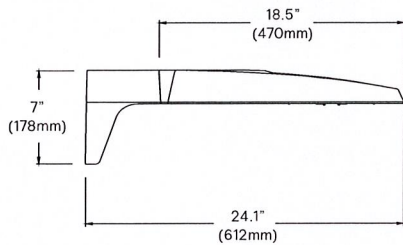
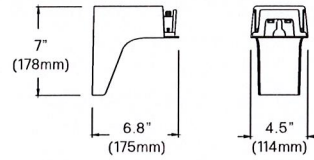
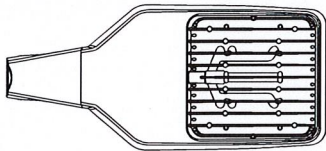

OptiForm Mast Arm

Weight: 12.6 lb (5.7 kg)

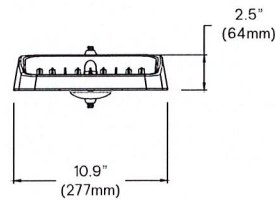
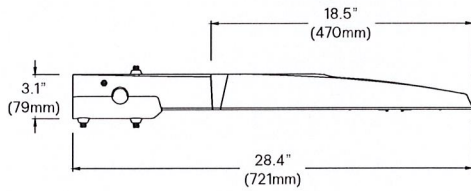
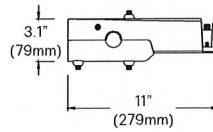
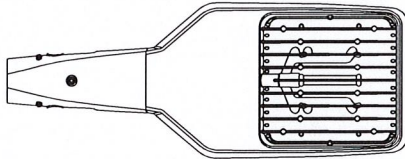

OptiForm Wall Mount

Weight: 11.5 lb (5.2 kg)

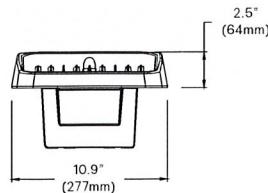
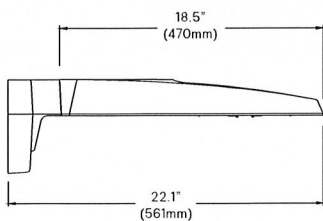
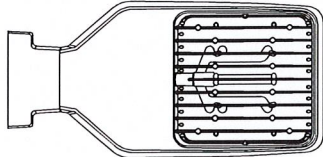



OPF-S OptiForm small

Site & area luminaire

Specifications

Housing

Housing and door constructed of low copper die cast Aluminum alloy (A360) with detachable arms for quick mounting. Heatsink is integral to the housing providing passive cooling of LEDs to maintain long LED life. Luminaire housing rated to IP65, LED Modules rated IP66 tested in accordance to Section 9 of IEC 60598-1.

Vibration resistance

OptiForm is tested and rated to standards set forth in ANSI C136.31-2018 Level 2 for Bridge and Overpass applications.

Light engine

Light engine comprises of a module of 40-LED aluminum metal clad board fully sealed with optics: Medium = 2 Modules with 80 LEDs, Large = 4 modules with 160 LEDs. Module is RoHS compliant. Color temperature as per ANSI/NEMA bin 2700 Kelvin nominal (2725 ±145K), 3000 Kelvin nominal (3045K +/- 175K) or 4000 Kelvin nominal (3985K +/- 275K), CRI 70 Min. 75 Typical. Other CCT/CRI also available, consult factory. LED light engine is rated IP66 in accordance to Section 9 of IEC 60598-1.

Energy saving benefits

System efficacy up to 182 lms/W with significant energy savings over Pulse Start Metal Halide luminaires. Optional control options provide added energy savings during unoccupied periods.

Optical systems

Site and Area optical distributions include Types 2 Medium, 3 Medium, 4 Medium, 4 Wide, 5 Narrow, 5 Medium, 5 Wide, and Auto Front Row. LEED Corner Left, LEED Corner Right, and Backlight Control distributions also available to provide excellent cutoff to meet the most stringent requirements at property lines. Optional internal shields mount to LED optics and are available with Type 2M, 3M, and 4M distributions. Types 2M and 3M can be rotated at 90° or 270° when specified, and are factory set only. Site and Area optics shall be performance tested per LM-79 and TM-15 (IESNA) certifying their photometric performance. Luminaire designed with 0% uplight (U0 per IESNA TM-15).

Precision Plus optical distributions include Types 2, 3, 4 and 5 and are designed to illuminate pedestrian scale applications by providing lower glare, while still achieving desired distribution, optimized spacing, and excellent uniformity. Optics are made of optical grade polymer refractor lenses and shall be performance tested per LM-63, LM-79 and TM-15 (IESNA) certifying their photometric performance. Luminaire designed with 0% uplight (U0 per IESNA TM-15).

Mounting

Standard luminaire arm mounts to square poles with knock-out on the arm to allow for mounting to 4" O.D. round poles. Standard arm casting can accommodate existing bolt spacing from 2" to 4-7/8". It is recommended to use the bolster plate kit OPF RMB when it's not a new installation or if the mounting holes are larger than 0.41" (10mm).

OptiForm features a Mast Arm for Mounting to 2-3/8x4" tenon as well as wall mount casting for exterior building mount applications.

Control options

Dimming Leads Externally Accessible (DLEA): Access to 0-10V dimming leads supplied through back of luminaire (for secondary dimming controls by others). Cannot be used with other control options.

Sensor Ready Zhaga Socket Connector (SRDR): Product is D4i Certified and equipped with Sensor Ready drivers connected to 4-pin Zhaga Book 18 compliant receptacle designed for sensor and other control system applications. Receptacle is rated IP66 assembly in a compact design that provides a sealed electrical interface and rated UV resistance, mounted on underside of the luminaire, protective dust cap included. When a controller not provided by Signify is used with Sensor Ready Zhaga socket connector, the controller must be certified to work with the Xitanium SR LED drivers as part of the SR certified program. SRDR can be used with NEMA 7-pin twist lock receptacle, which is mounted on top of the luminaire.

Automatic Profile Dimming (CS/CM/CE/CA): Standard dimming profiles provide flexibility towards energy savings goals while optimizing light levels during specific dark hours. Dimming profiles include two dimming settings including dim to 30% or 50% of the total lumen output. When used in combination with not programmed motion response it overrides the controller's schedule when motion is detected. After 5 minutes with no motion, it will return to the automatic dimming profile schedule. Automatic dimming profile scheduled with the following settings:

- **CS50/CS30:** Security for 7 hours night duration (Ex., 11 PM - 6 AM)
- **CM50/CM30:** Median for 8 hours night duration (Ex., 10 PM - 6 AM)

All above profiles are calculated from mid point of the night. Dimming is set for 6 hours after the mid point and 1 or 2 hours before depending of the duration of dimming. Cannot be used with other dimming control options

Field Adjustable Wattage Selector (FAWS): Luminaire equipped with the ability to manually adjust the wattage in the field to reduce total luminaire lumen output and light levels. Comes pre-set to the highest position lumen output selected. Use chart below to estimate reduction in lumen output desired. Cannot be used with other control options or motion response.

FAWS Position	Percent of Typical Lumen Output	FAWS Position	Percent of Typical Lumen Output
1	25%	6	80%
2	50%	7	85%
3	55%	8	90%
4	65%	9	95%
5	75%	10	100%

Note: Typical value accuracy +/- 5%

Motion response options

Bi-Level Infrared Motion Response (BL50): Motion Response module is mounted integral to luminaire factory pre-programmed to 50% dimming when not ordered with other control options. BL-IMRI is set/operates in the following fashion: The motion sensor is set to a constant 50%. When motion is detected by the PIR sensor, the luminaire returns to full power/light output. Dimming on low is factory set to 50% with 5 minutes default in "full power" prior to dimming back to low. When no motion is detected for 5 minutes, the motion response system reduces the wattage by 50%, to 50% of the normal constant wattage reducing the light level. Other dimming settings can be provided if different dimming levels are required (contact Technical Support for details).

Infrared Motion Response with Other Controls: When used in combination with other controls (Automatic Dimming Profile), motion response device will simply override controller's schedule with the added benefits of a combined dimming profile and sensor detection. In this configuration, the motion response device cannot be re-programmed with FSIR-100 Wireless Remote Programming Tool. The profile can only be re-programmed via the controller.

Infrared Motion Response Lenses (L2): Infrared Motion Response Integral module is available with two different sensor lens types to accommodate various mounting heights and occupancy detection ranges. Lens #2 is designed for mounting heights 8' to 15'. Lens #3 is designed for higher mounting heights up to 20' with a 40' diameter coverage area. See charts for approximate detection patterns:

Luminaire with #2 lens

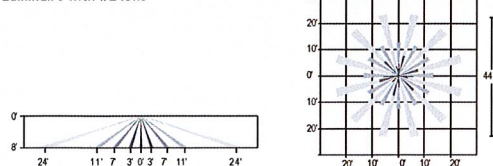

Submitted by Leslie Nowalski



CHICAGO
LIGHTWORKS

Job Name:

ORTHOPEDIC SPECIALISTS OF
NWI OSNI
Electrical Contractor: PALOS
ELECTRIC-CRESTWOOD

Catalog Number:

OPF-S-A05-840-T4M-AR1-UNV-BZ

Notes:

Type:

F1

CLW24-28520

OPF-S OptiForm small

Site & area luminaire

Specifications (cont'd)

Electrical

Twist-Lock Receptacle (TR5/TR7): Twist Lock Receptacle with 5 pins enabling dimming or with 7 pins with additional functionality (by others) can be used with a twistlock photoelectric cell or a shorting cap. Dimming Receptacle Type B (5-pin) and Type D-24 (7-pin) in accordance to ANSI C136.41. Can be used with third-party control system. Receptacle located on top of luminaire housing. When specifying receptacle with twistlock photoelectric cell, voltage must be specified. When ordering 7-pin Twist-lock receptacle (TR7), all 7 pins are wired to respective pins with the Sensor Ready (SR) driver, and photocell or shorting cap is not included. When ordering a twist-lock receptacle with a photocell (TLP), the receptacle used is a 7-pin receptacle, with pins 6 and 7 connected to SR DALI driver. 0-10V dimming leads (pins 4 and 5) are connected if not ordered with any other dimming option.

Driver: Driver efficiency (>90% standard). 120-480V available (restrictions apply). Open/short circuit protection. All drivers are 0-10V dimming to 10% power standard, except when using Sensor Ready (SR) drivers, which uses DALI protocol (options CS50/CM50/CS30/CM30, SRDR, and TR7). Drivers are RoHS and FCC Title 47 CFR Part 15 compliant.

Button Photocontrol (PCB): Button style design for internal luminaires mounting applications. The photocontrol is constructed of a high impact UV stabilized polycarbonate housing. Rated voltage of 120V or 208-277V with a load rating of 1000 VA. The photocell will turn on with 1-4Fc of ambient light.

Surge protection (SP1/SP2): Surge protection device tested in accordance with ANSI/IEEE C62.45 per ANSI/IEEE C62.41.2 Scenario I Category C High Exposure 10kV/10kA waveforms for Line-Ground, Line-Neutral and Neutral-Ground, and in accordance with DOE MSSLC Model Specification for LED Roadway Luminaires Appendix D Electrical Immunity High test level 10kV/10kA, 20kV / 10kA surge protection device that provides extra protection beyond the SP1 10kV/10kA level.

Listings

UL/cUL wet location listed to the UL 1598 standard, suitable for use in ambient temperatures from -40° to 40°C (-40° to 104°F). All OptiForm configurations are qualified under Design Lights Consortium Premium classification. Consult DLC Qualified Products list to confirm your specific luminaire selection is approved. CCTs 3000K and warmer are Dark Sky Approved.

Finish

Each standard color luminaire receives a fade and abrasion resistant, electrostatically applied, thermally cured, triglycidal isocyanurate (TGIC) textured polyester powdercoat finish. Standard colors include bronze (BZ), black (BK), white (WH), dark gray (DGY), and medium gray (MGY). Consult Factory for specs on optional, custom colors, and marine grade paint.

Service Tag

Each individual luminaire is uniquely identifiable, thanks to the Service tag application. With a simple scan of a QR code, placed on the inside of the mast door, you gain instant access to the luminaire configuration, making installation and maintenance operations faster and easier, no matter what stage of the luminaire's lifetime. Just download the APP and register your product right away. For more details visit: signify.com

Warranty

OptiForm luminaires feature a 5-year limited warranty. See signify.com/warranties for complete details and exclusions.

Buy American Act of 1933 (BAA):

This product is manufactured in one of our US factories and, as of the date of this document, this product was considered a commercially available off-the-shelf (COTS) item meeting the requirements of the BAA. This BAA designation hereunder does not address (i) the applicability of, or availability of a waiver under, the Trade Agreements Act, or (ii) the "Buy America" domestic content requirements imposed on states, localities, and other non-federal entities as a condition of receiving funds administered by the Department of Transportation or other federal agencies. Prior to ordering, please visit www.signify.com/baa to view a current list of BAA-compliant products to confirm this product's current compliance.



© 2023 Signify Holding. All rights reserved. The information provided herein is subject to change, without notice. Signify does not give any representation or warranty as to the accuracy or completeness of the information included herein and shall not be liable for any action in reliance thereon. The information presented in this document is not intended as any commercial offer and does not form part of any quotation or contract, unless otherwise agreed by Signify.

Signify North America Corporation
400 Crossing Blvd, Suite 600
Bridgewater, NJ 08807
Telephone: 800-555-0050

Signify Canada Ltd.
281 Hillmount Road,
Markham, ON, Canada L6C 2S3
Telephone: 800-668-9008

All trademarks are owned by Signify Holding or their respective owners.

Submitted by Leslie Nowalski



CHICAGO LIGHTWORKS

Job Name:
ORTHOPEDIC SPECIALISTS OF
NWI OSNI
Electrical Contractor: PALOS
ELECTRIC-CRESTWOOD

Catalog Number:

SSS-CB-4-7-23-D1-DT5-BZ, AB 3/
4X24X3-G DEC W/ 8.5 BC ABT

Notes:

Type:

F1

CLW24-28520



Poles & Brackets

Site and Area Poles

Straight Square Steel

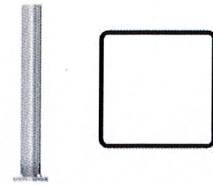

Project: _____
Location: _____
Cat.No: _____
Type: _____
Notes: _____

The Gardco SSS Straight Square Steel pole consists of a one-piece high tensile carbon steel tube welded and secured to the carbon steel base plate providing excellent strength and integrity. The poles are finished with an electrostatically applied, thermally cured polyester powdercoat. All poles include base cover, hand hole, ground lug and top cap. Anchor bolts and templates are ordered as a separate accessory.

Ordering guide

example: SSS-CB-4-11-12-D1-DT1-BK-FES

Family	Base	Pole Shaft Size (In.)	Pole Gauge/Wall Thickness	Height (ft) *	Drilling/Tenon Configurations ¹	Drilling Template ²	Finish	Options ³
	CB			23				
SSS	CB Carbon Steel Base w/ Base Cover	4	11 11 ga. / 0.120"	10	D1 1 Way D1@180 1 Way @ 180 D2 2 Way @ 180 D2@90 2 Way @ 90 D3 3 Way @ 90 D4 4 Way @ 90	DT1 Drill Template 1 DT2 Drill Template 2 DT3 Drill Template 3 DT4 Drill Template 4 DT5 Drill Template 5 DT6 Drill Template 6 [DTX-xxx] ^{4,7} Custom Template See drill template chart for details.	BK Black BZ Bronze WH White DG Dark Grey MG Medium Grey GY ⁸ Light Grey, Smooth SSDGY ⁸ SolarForm Dark Grey (RAL 7011) GV Galvanized (No Paint) FP/GV Finished Textured Paint over Galvanized (Specify, ex: MG/GV)	FES ⁶ Festoon Outlet VDA Vibration Dampener AHH ⁶ Additional Hand Hole DR ^{6,8} Duplex Receptacle VPA Vandalproof Screws GFI ^{6,8} DR with GFI (120V only) BAC ⁹ Buy American Compliant CL1/2 ⁶ Coupling 1/2" CL3/4 ⁶ Coupling 3/4" CL1 ⁶ Coupling 1" CL1-1/4 ⁶ Coupling 1-1/4" CL1-1/2 ⁶ Coupling 1-1/2" NL1/2 ⁶ Nipple 1/2" NL3/4 ⁶ Nipple 3/4" NL1 ⁶ Nipple 1" NL1-1/4 ⁶ Nipple 1-1/4" NL1-1/2 ⁶ Nipple 1-1/2"
				12				
				14				
				15				
				16				
				18				
		20						
		25						
		30						
		7 7 ga. / 0.180"	20	T2D4L 2-3/8" OD x 4" length T2D6L " 2-3/8" OD x 6" length T3D4L 3" OD x 4" length T4D6L 4" OD x 6" length	N No Drilling Template (for Tenon and Plain Top Options)	OC Optional Color Paint (ex: RAL7024) SC ⁶ Special/ Custom Color (Specify, must supply color chip)		
		25						
		25						
30								
35								
40								
L/SSS	6	7 7 ga. / 0.180"	30	No Drilling/No Tenon	P Plain Top			

- See Drilling Configurations on Page 3.
- See Luminaire Drilling Templates on Page 3.
- Not all options available with all configurations. Consult factory for more details.
- Options listed with gray text will be shipped with the Legacy SSS design. Use the L/SSS family code whenever these options are specified.
- Pole heights can be cut to length. Specify as a whole number in ft. (ex. 11, 13) or to the inch as a decimal (ex. 15.33 = 15' 4") or as "15FT 4IN" for Legacy designs.
- Option must be specified, including install location, by the customer before order release. FES, DR, GFI, AHH options typically must be placed 12-18" away from standard hand hole (20" or 12" above base).

- Custom drill templates (DTX) require factory quote.
- Option not available with Legacy SSS designs.
- Failure to properly select the "BAC" suffix could result in you receiving product that is not BAA compliant product with no recourse for an RMA or refund. This BAC designation hereunder does not address (i) the applicability of, or availability of a waiver under, the Trade Agreements Act, or (ii) the "Buy America" domestic content requirements imposed on states, localities, and other non-federal entities as a condition of receiving funds administered by the Department of Transportation or other federal agencies.
- Consult Signify to confirm whether specific accessories are BAA-compliant.

Accessories ¹⁰

Service	Pole Size	12NC	Description (Diameter x Length x Hook)
Anchor Bolts + Templates			
For shipment with the pole (order 1 per pole)	4" Poles	912401597397	AB 3/4x24x3-G DEC w/ 8.5 BC ABT
	5" Poles	912401613107	AB 1x33x3-G DEC w/ 11 BC ABT
	6" Poles	912401597401	AB 1x33x3-G DEC w/ 12 BC ABT
For Pre-Ship service (order 1 per pole)	4" Poles	912401597405	AB 3/4x24x3-G DEC w/ 8.5 BC ABT-RS
	5" Poles	912401613106	AB 1x33x3-G DEC w/ 11 BC ABT-RS
	6" Poles	912401597408	AB 1x33x3-G DEC w/ 12 BC ABT-RS
Part No.	Description		
RLAR-1A-SQ4+ -(finish)	Cast aluminum mounting arm, 15" long with DT6 drill pattern (order 1 per luminaire). For use with Lumec Roadway and Gardco SolarForm luminaires (for SolarForm: use RLAR bracket to mount horizontally, use T2D6L tenon to mount vertically). Specify finish to match pole.		



RLAR



Poles Straight Square Steel

Dimensions

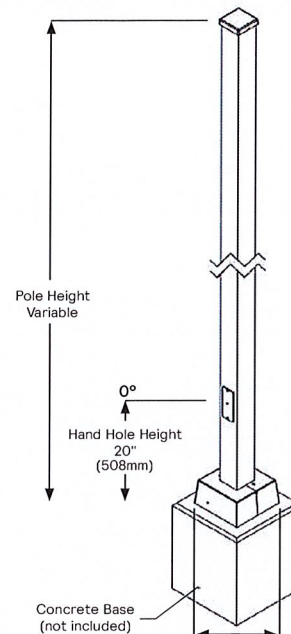
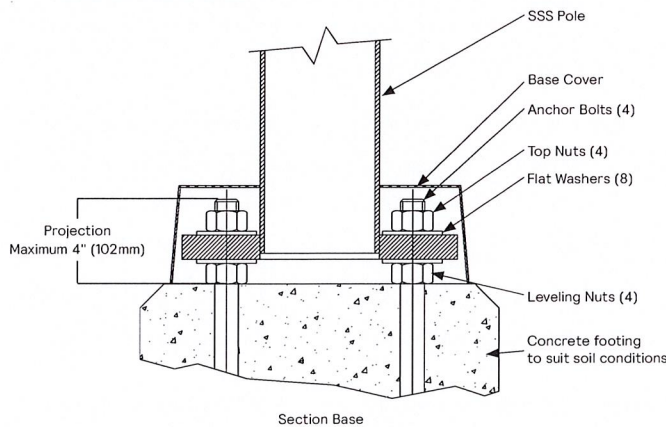
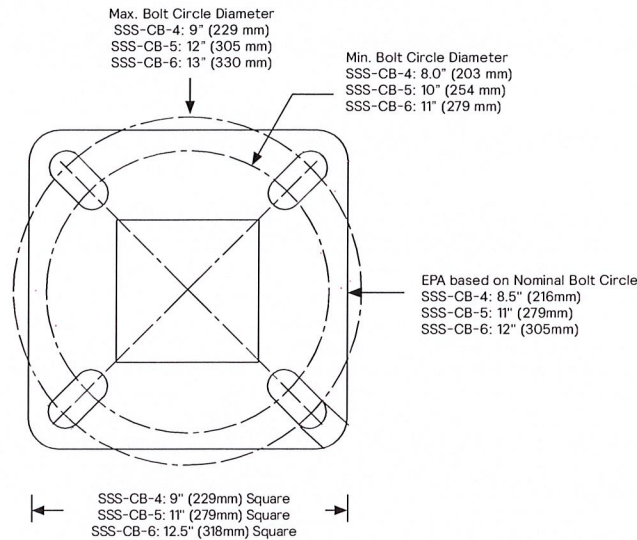

Base Cover Dimensions (L x W x H)
SSS-CB-4: 9.80" x 9.80" x 4.58" (245mm x 245mm x 116mm)
SSS-CB-5: 11.80" x 11.80" x 4.58" (300mm x 300mm x 116mm)
SSS-CB-6: 13.30" x 13.30" x 4.58" (338mm x 338mm x 116mm)

SSS Legacy Design not shown.
Base Cover: Square
Hand Hole: 12" Above Base

- * Anchor Bolt Lock Washers are not normally required and are not included in standard anchor bolt sets. They are available upon request at additional cost.
- ** Grouting should include a drainage slot or tube (by others) to permit water to drain from the base of the pole. Failure to provide drainage may weaken the pole base structure over time and may result in pole base failure, for which Gardco is not responsible.

NOTE: Factory supplied template must be used when setting anchor bolts. Gardco will not honor any claim for incorrect anchorage placement from failure to use factory supplied templates.



Poles Straight Square Steel

Drilling Configuration

Code	Description
D1	Single luminaire
D1@180	Single luminaire @ 180
D2	Two luminaires @ 180
D2@90	Two luminaires @ 90
D3	Three luminaires @ 90
D4	Four luminaires @ 90

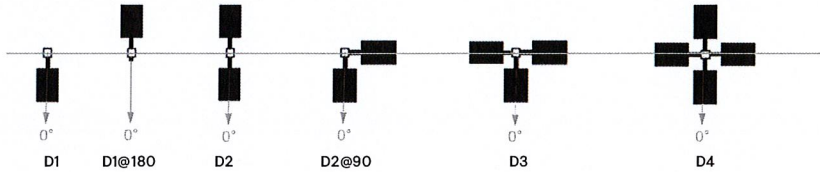

Ref. access door at 0° for all
Legacy design places access door at 180°

Tenon Dimensions

Tenon	Diameter	Height
T2D4L	2.375" (60mm)	4" (102mm)
T2D6L	2.375" (60mm)	6" (152mm)
T3D4L	3" (76mm)	4" (102mm)
T4D6L	4" (102mm)	6" (152mm)

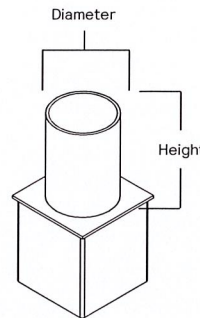

Pole Top Drilling

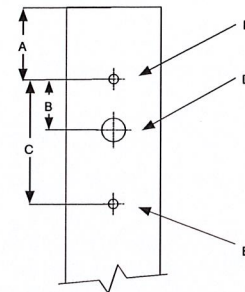

Luminaire Drill Pattern

Code	Description	Luminaires	Pole Drilling				
			A To Pole Top	B	C Full Extent	D Wireway Hole	E Bolt Hole
DT1	Drill Template 1	Gardco SlenderForm Round SFRA	2.25" (57mm)	1.5" (38.1mm)	3" (76mm)	0.875" (22.2mm)	0.40" (10.2mm)
DT2	Drill Template 2	Gardco SlenderForm Square - SFA Gardco Gullwing - GL13, GL18 Gardco Form Ten - EH14L, EH19L, CAL17, CAL22, MAL17, MAL22	2.25" (57mm)	2.17" (55mm)	3.84" (98mm)	0.875" (22.2mm)	0.39" (9.9mm)
DT3	Drill Template 3	Gardco PowerForm PFAS	2.25" (57mm)	1.75" (44mm)	3.84" (98mm)	0.875" (22.2mm)	0.41" (10.4mm)
DT4	Drill Template 4	Gen1 Stonco/Keene AL150-G1, AL200-G1	2.5" (64mm)	1.7" (43mm)	3.5" (89mm)	0.875" (22.2mm)	0.41" (10.4mm)
DT5	Drill Template 5	Gardco EcoForm Gen2 - ECF-S, ECF-L Gardco PureForm Gen2 - P15, P20, P26, P34 OptiForm Small - OPF-S OptiForm Med - OPF-M OptiForm Large - OPF-L	3" (76mm)	1" (25mm)	3" (76mm)	1" (25mm)	0.41" (10.4mm)
DT6	Drill Template 6	Hole pattern drilled for the following: Gen2 Stonco/Keene AL70-G2 and AL150-G2, or to attach RLAR bracket accessory, suitable for use with: Lumec Capella CPLM, CPLS Lumec RoadStar GPLM, GPLS Lumec RoadFocus RFS, RFM, RFL Lumec RoadView RVM, RVS Lumec MiniView SVS Lumec StreetView SVM Gardco SolarForm BRP710	2.5" (64mm)	1" (25mm)	2" (50mm)	0.875" (22mm)	0.5" (12.7mm)



Poles Straight Square Steel

Pole Data

Product Catalog Number	Pole Specs				Anchor Bolt Data			
	Height (ft.)	Pole Diameter (in.)	Wall Thickness (in.)	Pole Weight (lbs)	Bolt Circle (in.)	Anchor Bolt Spec (in.)	Legacy Anchor Bolt Spec (in.)	Anchor Bolt Max Proj. (in.)
SSS-CB-4-11-10	10	4	0.12	63	8.5 (+/- 0.5)	3/4 x 24 x 3	3/4 x 24 x 3	4
SSS-CB-4-11-12	12	4	0.12	76	8.5 (+/- 0.5)	3/4 x 24 x 3	3/4 x 24 x 3	4
SSS-CB-4-11-14	14	4	0.12	88	8.5 (+/- 0.5)	3/4 x 24 x 3	3/4 x 24 x 3	4
SSS-CB-4-11-15	15	4	0.12	94	8.5 (+/- 0.5)	3/4 x 24 x 3	3/4 x 24 x 3	4
SSS-CB-4-11-16	16	4	0.12	101	8.5 (+/- 0.5)	3/4 x 24 x 3	3/4 x 24 x 3	4
SSS-CB-4-11-18	18	4	0.12	113	8.5 (+/- 0.5)	3/4 x 24 x 3	3/4 x 24 x 3	4
SSS-CB-4-11-20	20	4	0.12	126	8.5 (+/- 0.5)	3/4 x 24 x 3	3/4 x 24 x 3	4
SSS-CB-4-11-25	25	4	0.12	157	8.5 (+/- 0.5)	3/4 x 24 x 3	3/4 x 24 x 3	4
SSS-CB-4-7-20	20	4	0.18	185	8.5 (+/- 0.5)	3/4 x 24 x 3	3/4 x 24 x 3	4
SSS-CB-4-7-25	25	4	0.18	232	8.5 (+/- 0.5)	3/4 x 24 x 3	3/4 x 24 x 3	4
● SSS-CB-4-7-30	30	4	0.18	278	8.5 (+/- 0.5)	3/4 x 24 x 3	3/4 x 24 x 3	4
SSS-CB-5-11-20	20	5	0.12	158	11 (+/- 1)	1 x 33 x 3	3/4 x 24 x 3	4
SSS-CB-5-11-25	25	5	0.12	197	11 (+/- 1)	1 x 33 x 3	3/4 x 24 x 3	4
● SSS-CB-5-11-30	30	5	0.12	237	11 (+/- 1)	1 x 33 x 3	3/4 x 24 x 3	4
SSS-CB-5-7-20	20	5	0.18	234	11 (+/- 1)	1 x 33 x 3	3/4 x 24 x 3	4
SSS-CB-5-7-25	25	5	0.18	292	11 (+/- 1)	1 x 33 x 3	3/4 x 24 x 3	4
● SSS-CB-5-7-30	30	5	0.18	350	11 (+/- 1)	1 x 33 x 3	3/4 x 24 x 3	4
● SSS-CB-5-7-35	35	5	0.18	409	11 (+/- 1)	1 x 33 x 3	3/4 x 24 x 3	4
● SSS-CB-6-7-30	30	6	0.18	423	12 (+/- 1)	1 x 33 x 3	1 x 33 x 3	4
● SSS-CB-6-7-35	35	6	0.18	493	12 (+/- 1)	1 x 33 x 3	1 x 33 x 3	4
● SSS-CB-6-7-40	40	6	0.18	564	12 (+/- 1)	1 x 33 x 3	1 x 33 x 3	4

● SSS Legacy Design

Standard Anchor Bolt

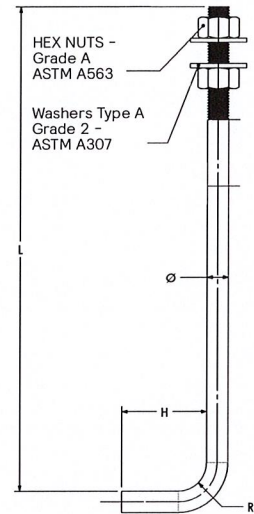

Pole Data (cont.)

Product Catalog Number	AASHTO 2001 - EPA ft ²								CSA - EPA ft ²							
	80 MPH	90 MPH	100 MPH	110 MPH	120 MPH	130 MPH	140 MPH	150 MPH	300 Pa 79 MPH	400 Pa 91 MPH	500 Pa 102 MPH	600 Pa 111 MPH	700 Pa 120 MPH	800 Pa 129 MPH	900 Pa 136 MPH	1000 Pa 144 MPH
SSS-CB-4-11-10	30.00	26.82	21.25	17.13	13.99	11.55	9.62	8.07	30.00	27.03	21.10	17.15	14.34	12.23	10.59	9.27
SSS-CB-4-11-12	28.31	21.72	17.04	13.55	10.88	8.83	7.19	5.88	30.00	21.74	16.76	13.44	11.08	9.30	7.92	6.82
SSS-CB-4-11-14	23.54	17.83	13.77	10.77	8.48	6.69	5.26	4.15	24.79	17.66	13.40	10.53	8.51	6.98	5.79	4.85
SSS-CB-4-11-15	21.53	16.22	12.41	9.57	7.43	5.76	4.44	3.36	22.58	15.92	11.94	9.30	7.40	5.96	4.87	3.97
SSS-CB-4-11-16	19.70	14.69	11.12	8.48	6.47	4.91	3.65	2.66	20.58	14.37	10.65	8.16	6.37	5.05	4.03	3.19
SSS-CB-4-11-18	16.19	11.82	8.72	6.43	4.67	3.30	2.21	1.33	17.07	11.59	8.31	6.12	4.56	3.38	2.47	1.74
SSS-CB-4-11-20	13.29	9.46	6.72	4.67	3.13	1.92	N/A	N/A	14.07	9.20	6.29	4.34	2.95	1.90	1.10	N/A
SSS-CB-4-11-25	7.78	4.86	2.78	1.22	N/A	N/A	N/A	N/A	7.95	4.26	2.06	N/A	N/A	N/A	N/A	N/A
SSS-CB-4-7-20	22.23	16.63	12.62	9.65	7.40	5.65	4.26	3.15	23.05	15.94	11.67	8.83	6.78	5.26	4.09	3.15
SSS-CB-4-7-25	14.87	10.59	7.54	5.28	3.56	2.23	1.16	N/A	14.83	9.42	6.17	4.01	2.46	1.31	N/A	N/A
● SSS-CB-4-7-30	9.63	6.25	3.82	2.01	N/A	N/A	N/A	N/A	8.36	4.20	1.72	N/A	N/A	N/A	N/A	N/A
SSS-CB-5-11-20	22.64	16.51	12.13	8.89	6.43	4.51	2.99	1.76	24.95	17.04	12.29	9.10	6.84	5.14	3.82	2.76
SSS-CB-5-11-25	14.32	9.62	6.25	3.79	1.90	N/A	N/A	N/A	16.16	10.00	6.29	3.83	2.06	N/A	N/A	N/A
● SSS-CB-5-11-30	8.28	4.53	1.86	N/A	N/A	N/A	N/A	N/A	9.30	4.42	1.48	N/A	N/A	N/A	N/A	N/A
SSS-CB-5-7-20	30.00	27.78	21.37	16.63	13.01	10.21	7.97	6.17	30.00	28.15	21.16	16.51	13.19	10.71	8.77	7.21
SSS-CB-5-7-25	25.42	18.54	13.62	9.97	7.19	5.05	3.34	1.98	27.74	18.68	13.23	9.61	7.02	5.08	3.56	2.37
● SSS-CB-5-7-30	17.45	11.94	8.01	5.08	2.88	1.16	N/A	N/A	18.54	11.33	7.02	4.12	2.07	N/A	N/A	N/A
● SSS-CB-5-7-35	11.37	6.84	3.62	1.22	N/A	N/A	N/A	N/A	10.73	5.08	1.70	N/A	N/A	N/A	N/A	N/A
● SSS-CB-6-7-30	27.54	19.44	13.66	9.38	6.14	3.59	1.57	N/A	30.00	20.55	13.99	9.59	6.47	4.11	2.27	N/A
● SSS-CB-6-7-35	19.06	12.39	7.60	4.05	1.36	N/A	N/A	N/A	21.06	12.23	6.96	3.42	N/A	N/A	N/A	N/A
● SSS-CB-6-7-40	12.29	6.64	2.60	N/A	N/A	N/A	N/A	N/A	12.21	5.17	N/A	N/A	N/A	N/A	N/A	N/A

- Warning: Additional wind loading, in terms of EPA, from banners, cameras, floodlights and other accessories attached to the pole, must be added to the luminaire(s) EPA before selecting the pole with the appropriate wind load capability. Specifying BAA or BAC compliant poles may result in different EPA ratings.
- Factory supplied template must be used when setting anchor bolts. Gardco will not honor any claim for incorrect anchorage placement resulting from failure to use factory supplied templates. Exact length of anchor bolts may vary.
- EPA ratings are based on the listed, optimal midpoint of the bolt circle. The bolt circle has limited variability but the EPA rating will change.

NOTE: Above EPA (Effective Projected Area) rating is in accordance with AASHTO 2001, with a 50 pound load (22.7 kg) placed at 1 foot (305mm) above its center.



Poles Straight Square Steel

Specifications

Pole shaft

The pole shaft is fabricated from a single piece of 11 ga (0.1196") or 7 ga (0.180") high tensile carbon steel. The formed steel plate is longitudinally welded providing minimum yield strength of 50 ksi. Shaft includes factory installed copper ground lug, 10-7 copper wire, and ground lug screw.

Anchor Base

The pole anchor base is fabricated from 44W structural quality carbon steel with a minimum yield strength of 44 ksi. The base plate is circumferentially welded on both top and bottom.

Anchor Bolts

Anchor bolts are fabricated from a commercial quality hot rolled carbon steel bar that meets or exceeds a minimum guaranteed yield strength of 55 ksi. Bolts have an "L" bend on one end and threaded on the opposite end. Anchor bolts are galvanized in accordance with ASTM A-153.6 C1.C. Four (4) properly sized bolts, each furnished with two (2) regular hex nuts and two (2) flat washers, are provided per pole (priced and ordered separately), unless otherwise specified. Conforms to AASHTO M 314 90 and ASTM F1554.

Customer Specified Options

The options, DTX, FES, DR, GFI, AHH, CL*, and NL* require factory quotation. Poles with custom drilling templates (DTX) are provided as a service, however Signify holds no liability for improper installation and safety when using non-Signify luminaires or attachments on Gardco poles via drilling, tenon mounting, or coupling and nipple mounting. It is the responsibility of the customer to ensure the pole is loaded and installed in a safe manner to the limitations of the pole structure. See "Warning" paragraph for more details.

Base Cover

A two-piece painted square aluminum base cover that completely conceals the entire base plate and anchorage. Base cover is provided standard. Legacy design is provided with a composite base cover.

Hand hole

The hand hole has a nominal rectangular 2"x4.5" inside opening in the pole shaft. Included is an aluminum cover plate, EPDM gasket, and captive attachment screws. The hand hole is located 20" above the base and 0° clockwise with respect to the luminaire arm when viewed from the top of the pole for one arm. For two arms the hand hole is located directly under one arm. Legacy design includes an easy to install, self-contained Swing Latch hand hole cover assembly. U.S. Patent Swing Latch cover is fabricated from durable polycarbonate/ABS blend plastic. All pole assemblies are provided with a 2.50" x 5.00" rectangular hand hole.

Pole Top Cap

Each pole assembly is provided with a removable aluminum pole top cap painted to match the specified pole and attached with two pressure screws. Legacy design is provided with a removable plastic top push cap. Finish is Black.

Finish

Poles are available with Gardco's standard textured color finishes - Black, White, Bronze, Dark Grey, Medium Grey, and Lumec GY3 for a match with roadway luminaire finishes. Optional Galvanized finish and custom colors also available. Legacy design is provided with gloss paint on standard finishes.

Couplings and Nipples

Couplings (NPSG standard internal threads) and Nipples (NPT standard external threads) are available to mount 3rd party objects to the pole. For most applications Couplings and Nipples must be at least 4' from the base of the pole. Lengths are as follows:

Couplings < 1" dia. = 1" length
 Couplings >= 1" dia. = 1.5" length
 Nipples < 1" dia. = 1.5" length
 Nipples >= 1" dia. = 2" length

Legacy pole designs may deviate from specifications listed here. See "Customer Specified Options" paragraph for more details.

Duplex Receptacle (DR and GFI)

DR and GFI options are placed at 2' below the pole top on the same side as the hand hole unless otherwise specified. DR or GFI options cannot be placed within 1' of the hand hole. Options can typically be placed 32" above base for utility purposes. Maximum output of the receptacles are 15A.

General Pole Information

Design

EPA specs conform to AASHTO 2001 standard. The poles as charted are designed to withstand dead loads and predicted dynamic loads developed by variable wind pressure with an additional 2.5 gust factor under the following conditions: The charted weights include luminaire(s) and/or mounting bracket(s). Poles installed in areas of known abnormal conditions may require special consideration. For example: coastal areas, airports and areas of special winds. Poles are designed for ground mounted applications. Poles mounted on structures (such as buildings and bridges) may also necessitate special consideration requiring Gardco's recommendation. Height correction factors and drag coefficients are applied to the entire structure. An appropriate safety factor is maintained based on the minimum yield strength of the material incorporated in the pole.

Warning

This design information is intended as a general guideline only. The customer is solely responsible for proper selection of pole, luminaire, accessory and foundation under the given site conditions and intended usage. The addition of any items to the pole, in addition to the luminaire, will dramatically impact the EPA load on that pole. It is strongly recommended that a qualified professional be consulted to analyze the loads given the user's specific needs to ensure proper selection of the pole, luminaire, accessories, and foundation. Gardco assumes no responsibility for such proper analysis or product selections. Failure to ensure proper site analysis, pole selection, loads and installation can result in pole failure, leading to serious injury or property damage.

Warranty

Gardco Steel poles are covered by a 3-year structural and finish warranty. Legacy designs are covered by a 1-year warranty. For more information visit signify.com/warranties



SIGN PERMIT APPLICATION RECEIVED 1.24.25

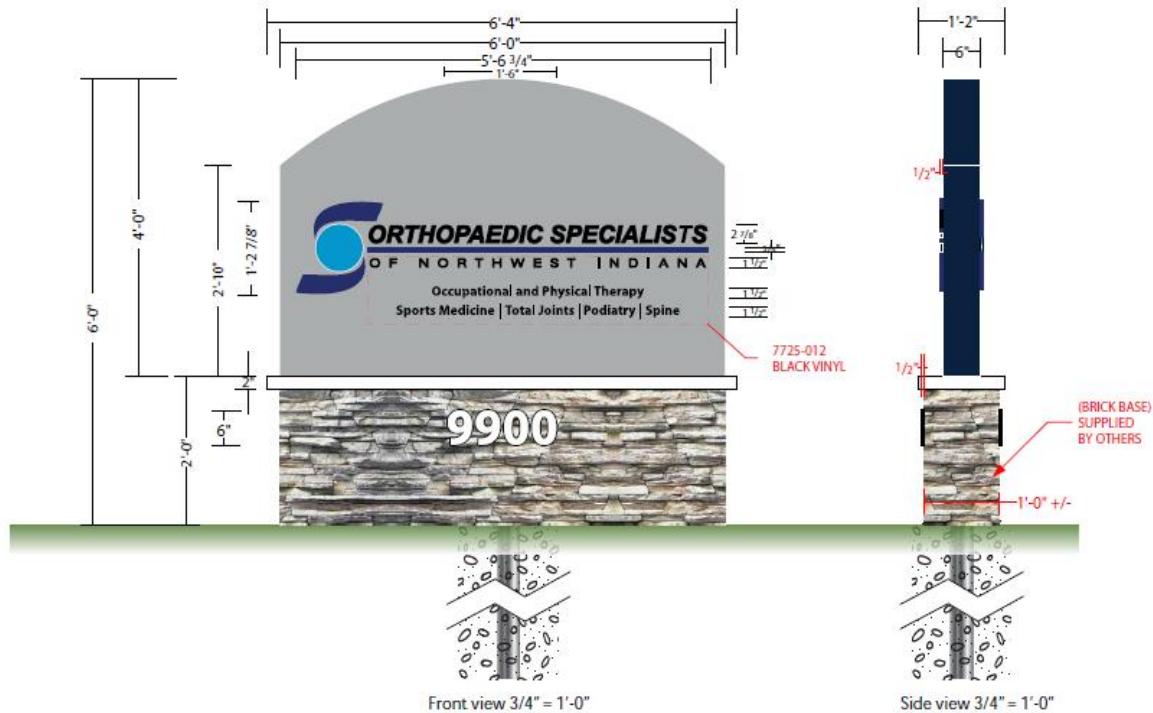

Outstanding items and compliance concerns:

- The aluminum sign face does not meet our sign standards - see attached sign standard regarding cabinet signs
- The square footage is 24 sf, which exceeds the 18 sf allowance
- Vinyl lettering does not meet the monument sign material standards
- The required landscaping is to be included with the sign permit application
- We need a site plan showing the location of the sign and the set back from the property line submitted with the application
- The brick base is to be included with the sign permit
- If the sign is to be externally illuminated, please provide the light specs
- All subcontractors are to be listed on the permit application
- We will need a contractor agreement(s) that include labor and materials cost for entire project (sign, base, electric, and landscaping)

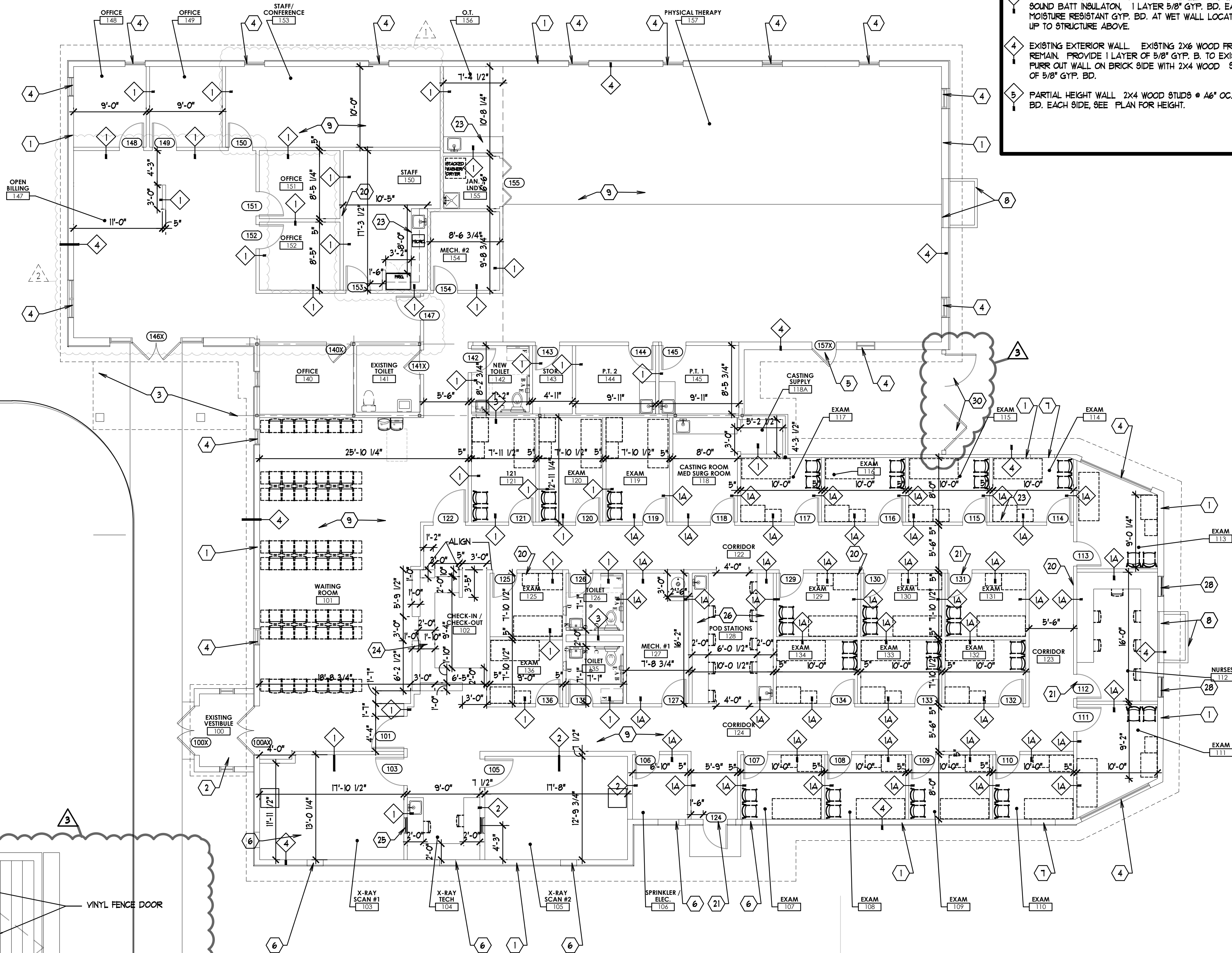

PROPOSED FLOOR PLAN
1/8" = 1'-0" A1.0

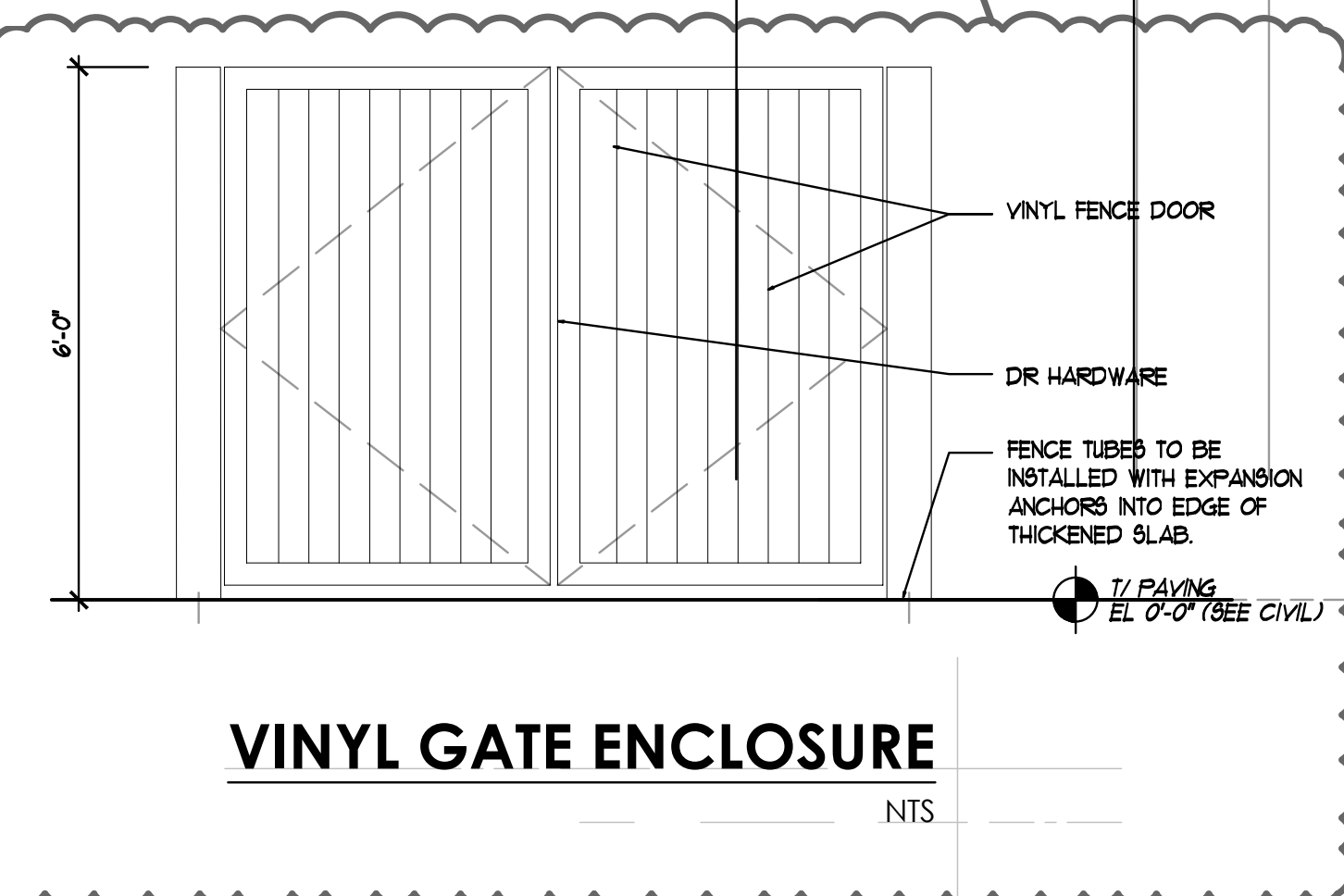

- ### PARTITION NOTES
- PARTITION TYPE NOTES
- 1 TYPICAL 2X4 WOOD STUD WALL, 2X4 WOOD STUDS, #16" O.C., SOUND BATT INSULATION, 1 LAYER 5/8" GYP. BD. EACH SIDE. EXTEND WALL TO STRUCTURE ABOVE.
 - 1A SAME AS TYPE 1, BUT EXTEND WALL TO 12'-0" AFF.
 - 2 XRAY ROOM WALLS TYPICAL 2X6 WOOD STUD WALL, 2X6 WOOD STUDS, #16" O.C., SOUND BATT INSULATION, 1 LAYER 5/8" GYP. BD. EACH SIDE. EXTEND WALL TO STRUCTURE ABOVE. WITH ADDED LEAD LINING TO 1'-0" AFF. SEE XRAY MANUFACTURER REQUIREMENTS.
 - 3 PLUMBING WALL. TYPICAL 2X6 WOOD STUDS, #16" O.C., SOUND BATT INSULATION, 1 LAYER 5/8" GYP. BD. EACH SIDE. USE MOISTURE RESISTANT GYP. BD. AT WET WALL LOCATION. EXTEND WALL UP TO STRUCTURE ABOVE.
 - 4 EXISTING EXTERIOR WALL. EXISTING 2X6 WOOD FRAMING AND BRICK TO REMAIN. PROVIDE 1 LAYER OF 5/8" GYP. B. TO EXISTING FRAMING. FLURR OUT WALL ON BRICK SIDE WITH 2X4 WOOD STUDS AND 1 LAYER OF 5/8" GYP. BD.
 - 5 PARTIAL HEIGHT WALL 2X4 WOOD STUDS @ 16" O.C. 1 LAYER 5/8" GYP BD. EACH SIDE, SEE PLAN FOR HEIGHT.

- ### GENERAL NOTES
- A. CONTRACTOR/S SHALL NOTIFY THE ARCHITECT OF ANY DISCREPANCIES IN FIELD BEFORE PROCEEDING WITH ANY WORK.
 - B. ALL DOOR HARDWARE TO MEET ADA ACCESSIBILITY GUIDELINES, SEE DR SCHEDULE.
 - C. COORDINATE GYPSUM BOARD APPLICATION W/ PARTITION TYPE DRAWINGS AND REFLECTED CEILING PLAN.
 - D. ALL GYPSUM BOARD PARTITION DIMENSIONS ARE FROM THE FINISHED FACE OF THE GYPSUM WALL BOARD, INC. DO NOT SCALE DRAWINGS, DIMENSIONS SHALL GOVERN. THE CONTRACTORS SHALL VERIFY ALL CONDITIONS AND DIMENSIONS IN THE FIELD BEFORE PROCEEDING WITH SUBSEQUENT WORK. THE OWNER/TECHNICAL AND/OR ARCHITECT SHALL BE NOTIFIED OF ANY DISCREPANCIES, WITH ALL DUE EXPEDIENCY, FOR CLARIFICATION PRIOR TO PROCEEDING WITH WORK.
 - E. ALL WOOD BLOCKING SHALL BE FIRE RESISTANCE IN ACCORDANCE WITH ALL APPLICABLE CODES AND GOVERNING AUTHORITIES.
 - F. THE CONTRACTOR SHALL SCHEDULE & COORDINATE THE LOCATION & INSTALLATION OF ALL WOOD BLOCKING & ELECTRICAL DEVICES PRIOR TO THE INSTALLATION OF THE GYPSUM WALL BOARDS & MILLWORK, AFTER CONSULTING THE OWNER FOR ELECTRICAL LOCATIONS.

- ### KEY NOTES
- 1 EXISTING PERIMETER BEARING STUD WALLS TO REMAIN, TYPICAL.
 - 2 EXISTING ENTRY VESTIBULE TO REMAIN, TO BE MODIFIED. EXISTING WALLS, WINDOW, DOORS AND FLOOR TO REMAIN. EXISTING SLOPED ROOF TO BE REMOVED AND REPLACED WITH NEW FLAT ROOF CONSTRUCTION. PROVIDE NEW FLAT CEILING AND NEW LIGHTING. SEE MECHANICAL.
 - 3 EXISTING EXTERIOR ENTRANCE CANOPY TO BE MODIFIED. EXISTING COLUMNS TO REMAIN. EXISTING SLOPED ROOF TO BE REPLACED WITH NEW FLAT ROOF CONSTRUCTION. PROVIDE NEW EXTERIOR CEILING, ROOFING AND RECESSED LIGHTS.
 - 4 EXISTING EXTERIOR WINDOW TO REMAIN.
 - 5 EXISTING EXTERIOR DOOR TO REMAIN.
 - 6 WHERE EXISTING EXTERIOR WINDOW WAS REMOVED, WALL TO BE FILLED FLUSH TO MATCH EXISTING ADJACENT, INCLUDING INTERIOR DRYWALL AND EXTERIOR CLADDING.
 - 7 WHERE EXISTING EXTERIOR DOOR WAS REMOVED, WALL TO BE FILLED FLUSH TO MATCH EXISTING ADJACENT, INCLUDING INTERIOR DRYWALL AND EXTERIOR CLADDING.
 - 8 EXISTING EXTERIOR TOWER TO REMAIN. EXISTING INTERIOR FIREPLACE AND CHIMNEY TO BE REMOVED. ON INTERIOR, FURNISH AND INSTALL NEW STUD/DRYWALL INFILL TO BE FLUSH WITH EXISTING ADJACENT.
 - 9 EXISTING CONCRETE FLOOR SLAB TO REMAIN, TYPICAL.
 - 20 NEW STUD WALL, TYPICAL.
 - 21 NEW DOOR, SEE DOOR SCHEDULE, TYPICAL.
 - 22 EXAM ROOMS - NEW COUNTER, BASE CABINETS, TO BE ADA ACCESSIBLE, TYPICAL.
 - 23 STAFF ROOM - NEW COUNTER, BASE CABINETS, UPPER CABINETS, SINK, TO BE ADA ACCESSIBLE.
 - 24 CHECK-IN / CHECK-OUT - NEW WORK COUNTER AND NEW UPPER COUNTER.
 - 25 NEW X-RAY VISION WINDOW, SEE X-RAY VENDOR REQUIREMENTS.
 - 26 #128 POD STATION TO HAVE NEW COUNTERS, TO BE ADA COMPLIANT.
 - 27 #141 OPEN BILLING, TO HAVE 3'-6" TALL PARTIAL HEIGHT WALLS, WITH COUNTERS, TO BE ADA ACCESSIBLE.
 - 28 NEW EXTERIOR WINDOW AND NEW LINTEL.

SITE WORK KEY NOTES

- 30 NEW FENCE TO SCREEN MECHANICAL UNITS, TO BE AS APPROVED BY THE MUNICIPALITY. SEE VINYL GATE ENCLOSURE DETAIL THIS SHEET.

01-24-2025

TYPICAL DOOR & WINDOW OPENINGS

ALUMINUM FRAMES		SEE PLAN FOR SWING DIRECTION	
SINGLE DOOR W/ SINGLE GLASS OR DBL FRAMED GLASS	SINGLE DOOR W/ MULTIPLE FRAMED GLASS	SEE PLAN FOR RM SIZE	SEE PLAN FOR RM SIZE
		SEE PLAN FOR RM SIZE	
HOLLOW METAL FRAMES		SEE PLAN FOR SWING DIRECTION	
CENTER DOOR OR WINDOW UNLESS DIMENSIONED OTHERWISE	SIDE DR & SINGLE WINDOW UNLESS DIMENSIONED OTHERWISE	SEE PLAN FOR RM SIZE	SEE PLAN FOR RM SIZE
		SEE PLAN FOR RM SIZE	

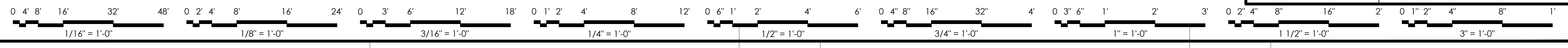

RIDGELAND ASSOCIATES INC.
ARCHITECTS DESIGNERS PLANNERS
1 Riverside Rd. Riverside, Illinois 60546
708.435.0300 708.435.0305 fax
www.ridgelandassociates.com

ZENON KURDZIEL
REGISTERED PROFESSIONAL ARCHITECT
STATE OF INDIANA
AR 1980045
EXPIRATION DATE: 12/31/2025

EAI
DESIGN/BUILD
E.ANTHONY, INC.
Complete Construction Services
708-602-6230

OSNI
BUILDING RENOVATION AND SITE WORK
9900 COLUMBIA AVENUE, MUNSTER, INDIANA 46321

Revisions

△	SITE FENCE UPDATE	01-24-2025
△	FIELD CHANGE	12-02-2024
△	FIELD CHANGE	11-20-2024
△	FOR PERM	08-13-2024

Drawing Date: _____
Project Number: 24038
This document is an instrument of service and is the sole property of Ridgeland Associates, Inc. It may not be copied, reproduced, altered or used in whole or in part on any other project without expressed written consent from Ridgeland Associates, Inc.
Sheet Name: **PROPOSED FLOOR PLAN**
Sheet Number: **A1.0**
© 2024 Ridgeland Associates, Inc.